



GUANGZHOU SANJING ELECTRIC CO.,LTD



Tel: (86)20 66608588 Fax: (86)20 66608589 Web: www.saj-electric.com

Add: SAJ Innovation Park, No.9, Lizhishan Road, Science City, Guangzhou High-tech Zone, Guangdong, P.R.China

V0.3



B2 Series

**RECHARGEABLE LI-ION BATTERY SYSTEM**

**USER MANUAL**

B2-7.3-HV5

B2-14.6-HV5

B2-21.9-HV5

# Preface

Thank you for choosing SAJ battery. We are pleased to provide you first-class products and exceptional service.

This manual includes information for installation, operation, maintenance, trouble shooting and safety. Please follow the instructions of this manual so that we can ensure delivery of our professional guidance and wholehearted service.

Customer-orientation is our forever commitment. We hope this document proves to be of great assistance in your journey for a cleaner, greener world.

Please check for the latest version at [www.saj-electric.com](http://www.saj-electric.com)

Guangzhou Sanjing Electric Co., Ltd.



# TABLE OF CONTENTS

<b>1. SAFETY PRECAUTIONS.....</b>	<b>1</b>
1.1 Scope of Application .....	2
1.2 Safety Instructions .....	2
1.3 Target Group .....	2
<b>2. PREPARATION .....</b>	<b>3</b>
2.1 Safety Instructions .....	4
2.2 Explanations Of Symbols .....	5
2.3 Battery Handling .....	6
2.4 Emergency Situation .....	6
<b>3. PRODUCT INFORMATION.....</b>	<b>9</b>
3.1 Application Scope of Products.....	10
3.2 Specification for Product Model.....	11
3.3 Overview of Products.....	11
3.4 Battery Terminals Description .....	12
3.5 Datasheet.....	13
<b>4. INSTRUCTIONS FOR INSTALLATION.....</b>	<b>15</b>
4.1 Unpacking and Inspection.....	16
4.1.1 Checking the Package.....	16
4.1.2 Scope of Delivery.....	16
4.2 Installation Method and Position.....	17
4.2.1 Installation Position and Clearance.....	17

4.2.2 Mounting Method .....	19
4.3 Mounting Procedure.....	20
4.3.1 Installation Tools.....	20
4.3.2 Installation Location.....	21
4.3.2.1 Ground Mounting (To wall).....	21
4.3.2.2 Wall Mounting (To wall) .....	24
4.3.2.3 Ground Mounting (To wood studs).....	29
<b>5. ELECTRICAL CONNECTION .....</b>	<b>35</b>
5.1 Additional Grounding Cable .....	36
5.2 Connecting Control Unit to Battery, Battery to Battery .....	38
5.3 Conduit installation(For North America) .....	39
5.4 Connecting Battery to Inverter.....	42
5.4.1 Single-Cluster Battery Connection .....	42
5.4.2 Multi-cluster Battery Connection .....	43
5.5 Communication Interface .....	44
<b>6. COMMISSIONING.....</b>	<b>45</b>
6.1 Start Up and Shut Down the Battery .....	46
6.1.1 Start Up .....	46
6.1.2 Shut Down.....	47
6.2 Introduction of Human-computer Interface .....	48
6.3 Commissioning.....	49
<b>7. Battery Maintenance .....</b>	<b>51</b>
7.1 Transportation.....	52
7.2 Storage .....	52
7.3 Maintenance .....	53
<b>8. Troubleshooting and Warranty .....</b>	<b>55</b>

## 1.1 Scope of Application

This User Manual describes instructions and detailed procedures for installing, operating, maintaining, and troubleshooting of the following SAJ products:

B2-7.3-HV5; B2-14.6-HV5; B2-21.9-HV5.

## 1.2 Safety Instructions

### DANGER

· DANGER indicates a hazardous situation which, if not avoided, will result in death or serious injury.

### WARNING

· WARNING indicates a hazardous situation which, if not avoided, can result in death or serious injury or moderate injury.

### CAUTION

· CAUTION indicates a hazardous condition which, if not avoided, can result in minor or moderate injury.

### NOTICE

· NOTICE indicates a situation that can result in potential damage, if not avoided.

## 1.3 Target Group

Only qualified electricians who have read and fully understood all safety regulations contained in this manual can install, maintain, and repair the battery. Operators must be aware of the high-voltage device.

# 1.

# SAFETY PRECAUTIONS



## 2.

## PREPARATION



## 2.1 Safety Instructions

For safety, be sure to read all the safety instructions carefully prior to any works, and please observe the appropriate rules and regulations of the country or region where you installed B2 battery.

 **DANGER**

- Please keep the power off prior to any operations
- Do not use the battery or the battery control unit if it is defective, broken or damaged.
- Do not expose the battery to temperatures in excess of 50°C.
- Do not subject the battery to any strong force.
- Do not place the battery near a heat source, such as direct sunlight, a fireplace.
- Keep inflammable and explosive dangerous items or flames away from the battery.
- Do not soak the battery in water or expose it to moisture or liquids.
- Do not use the battery in vehicles.
- Do not use the battery in areas where the ammonia content of the air exceeds 20ppm.

 **WARNING**

- Only qualified personnel who has full knowledge of local safety regulations and local standards on battery can install, maintain, retrieve and process this product.
- SAJ electric shall not be liable for any loss or warranty claims arising from any unauthorized change of product which may cause fatal injury to the operator, third party or equipment performance.
- For personal and property safety, do not short-circuit the positive (+) and negative (-) electrode terminals.









 **CAUTION**

- Do not modify or change any components in the battery.
- Risk of damage due to improper modification
- Use professional tools when operating the products.

 **NOTICE**

- During installation of the battery B2 high voltage battery, circuit breaker must be disconnected from the battery pack wiring.
- The battery B2 can only be used as a set with SAJ's H2 high voltage series storage inverter, otherwise it cannot be used normally.

## 2.2 Explanations of Symbols

Symbol	Description
	<b>Dangerous electrical voltage</b> This device is directly connected to public grid, thus all work to the battery shall only be carried out by qualified personnel.
	<b>No open flames</b> Do not place or install near flammable or explosive materials.
	<b>Danger of hot surface</b> The components inside the battery will release a lot of heat during operation. Do not touch metal plate housing during operating.
	<b>Attention</b> Install the product out of reach of children
	<b>An error has occurred</b> Please go to Chapter 7 to remedy the error.
	<b>This device shall NOT be disposed of in residential waste</b>
	<b>This battery module shall NOT be disposed of in residential waste</b>
	<b>Recyclable</b>

## 2.3 Battery Handling

Operate and use the battery properly according to user manual, any attempt to modify battery without the permission from SAJ will void the limit warranty for the battery.

- The battery must be installed at a suitable location with sufficient ventilation.
- Do not use the battery if it is defective, damaged or broken.
- Only use the battery with compatible inverter.
- Do not use the battery with other type of battery.
- Make sure the battery is grounded prior to use.
- Do not pull out any cables or open the battery enclosure when the battery is powered on.
- Only use the battery as intended and designed.
- It is recommended not to mix old and new battery modules, because doing so will not only cause capacity mismatch, but also affect battery performance and service life.
- It is recommended not to mix batteries with different SOC states, and better to use batteries from the same production batch together, because this can reduce the risk of abnormalities.
- If the user wants to expand the capacity later, it is recommended to add a cluster of batteries with the same configuration and use them in parallel with the original batteries.

## 2.4 Emergency Situation

Despite of its careful and professional protection design against any hazards, damage of the battery may still possible. If a small amount of battery electrolyte is released due to a serious damage of the outer casing; or if the battery explodes due to not being treated timely after a fire breaks out nearby, and leaks out poisonous gases such as carbon monoxide, carbon dioxide etc., the following actions are recommended:

- 1) Eye contact: Rinse eyes with a large amount of running water and seek medical advice.
- 2) Contact with skin: Wash the contacted area with soap thoroughly and seek medical advice.
- 3) Inhalation: If you feel discomfort, dizziness or vomiting, seek medical advice immediately.
- 4) Use a FM-200 or Carbon Dioxide (CO<sub>2</sub>) fire extinguishers to extinguish the fire if there is a fire in the area where the battery pack is installed. Wear a gas mask and avoid inhaling toxic gases and harmful substances produced by the fire.
- 5) Use an ABC fire extinguisher, if the fire is not caused by battery and not spread to it yet.

 **WARNING**

- If a fire has just occurred, try to disconnect the battery circuit breaker, and cut off the power supply first, but only if you can do so without endangering yourself.
- If the battery is on fire, do not attempt to extinguish the fire but evacuate the crowd immediately.

**Potential danger of damaged battery:**

**Chemical Hazard:** Despite of its careful and professional protection design against any hazard results, rupture of battery may still occur due to mechanical damage, internal pressure etc., and may result in a leakage of battery electrolyte. The electrolyte is corrosive and flammable. When there is fire, the toxic gases produced will cause skin and eyes irritation, and discomfort after inhalation. Therefore:

- 1) Do not open damaged batteries.
- 2) Do not damage the battery again (shock, fall, trample, etc.).
- 3) Keep damaged batteries away from water (except to prevent an energy storage system from catching fire).
- 4) Do not expose the damaged battery to the sun to prevent internal heating of the battery.

**Electrical hazard:** The reason of fire and explosion accidents in lithium batteries is battery explosion. Here are the main factors of battery explosion:

- 1) Short circuit of battery. Short circuit will generate high heat inside battery, resulting in partial electrolyte gasification, which will stretch the battery shell. The temperature reaching ignition point of internal material will lead to explosive combustion.
- 2) Overcharge of battery. Overcharge of battery may precipitate lithium metal. If the shell is broken, it will come into direct contact with the air, resulting in combustion. The electrolyte will be ignited at the same time, resulting in strong flame, rapid expansion of gas and explosion.

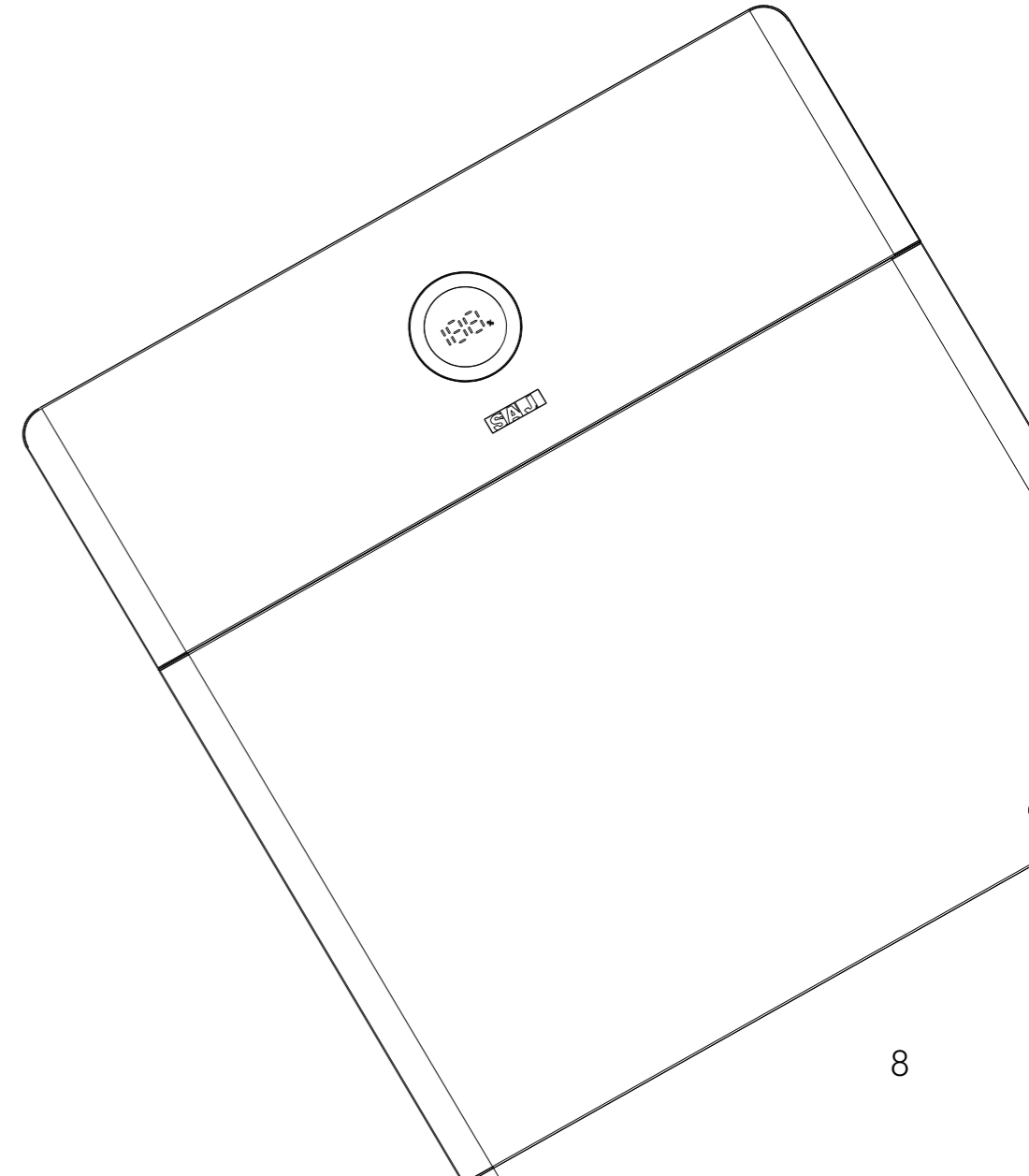

# 3.

# PRODUCT INFORMATION



## 3.1 Application Scope of Products

The B2 battery is applied to residential photovoltaic storage system. The battery is built internally with a battery management system (BMS), which is used to ensure efficiency of the battery and protect the battery from operating out of its specified limitations. B2 battery is a high voltage battery system. The battery employs modular design for easy installation and wiring.

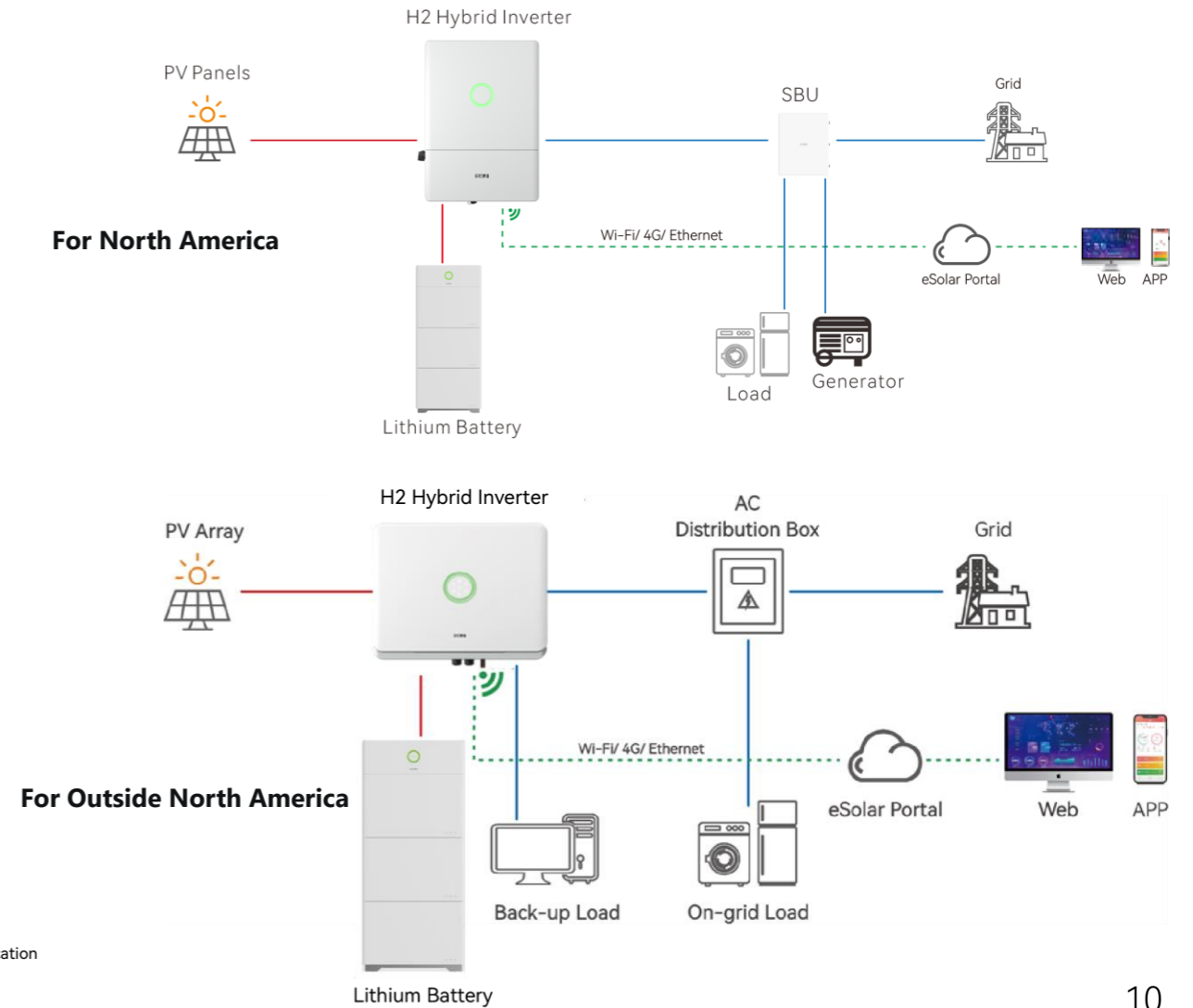

Figure 3.1  
B2 battery application



### 3.2 Specification for Product Model

**B2 - X.X - HV5**  
 ①      ②      ③

- ① B2 represents for product name.
- ② X.X represents rated energy XkWh of battery, for example, 7.3 means 7.3kWh.
- ③ HV means high voltage.

### 3.3 Overview of Products

Battery Module and Battery Control Unit

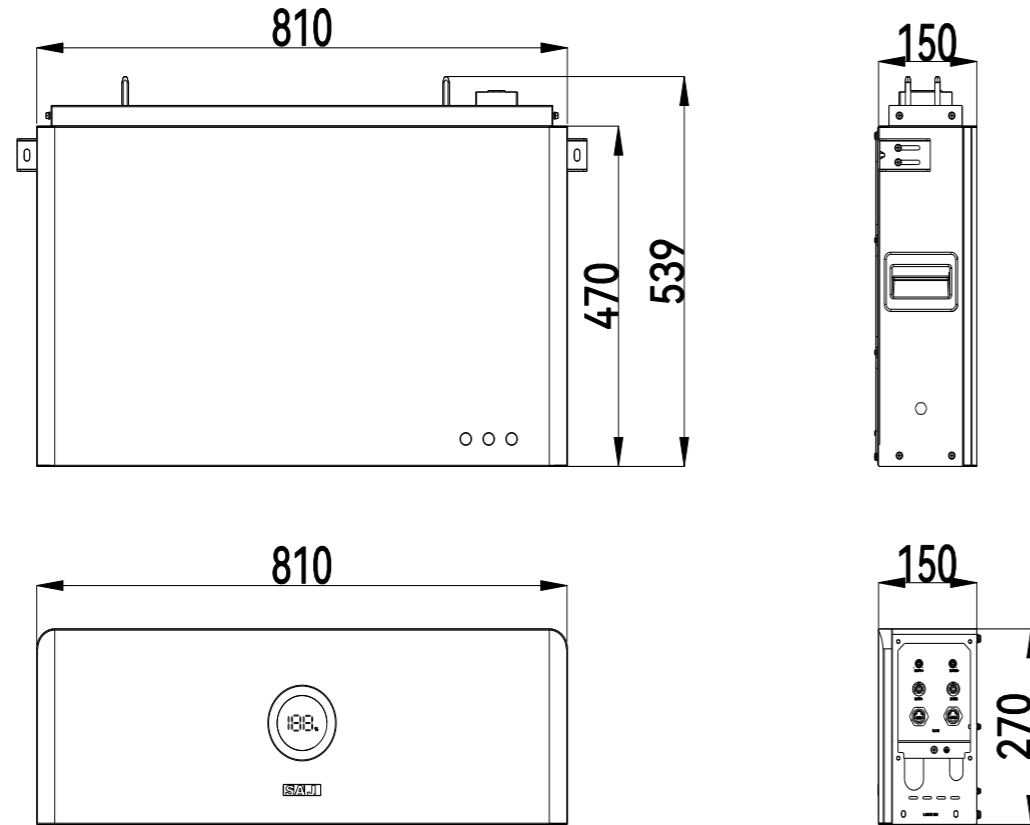

Figure 3.2  
Dimensions of battery module and control unit

Wall Bracket (Optional Component)

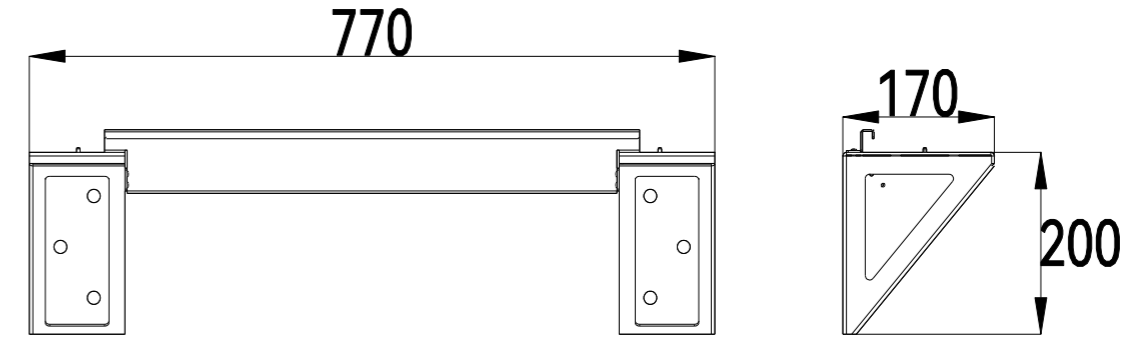

Figure 3.3  
Dimensions of wall bracket

### 3.4 Terminals Description

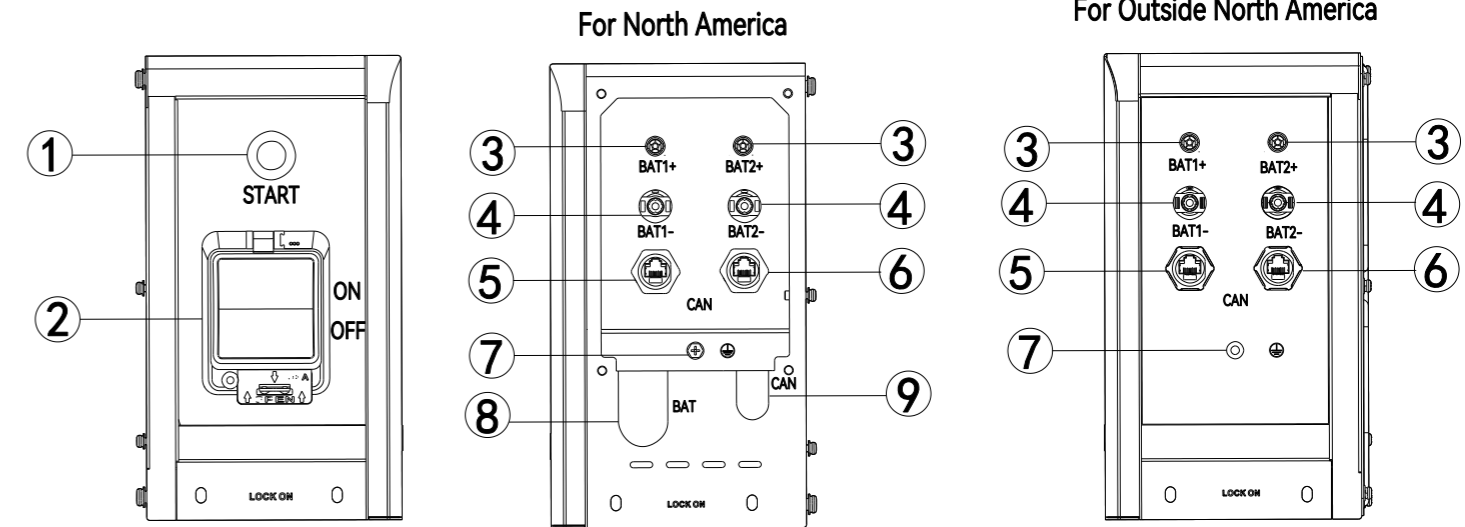

Figure 3.4 Battery control unit

Position	Name
1	Start button
2	Circuit breaker
3	BAT+ port (to inverter or for parallel connection)
4	BAT- port (to inverter or for parallel connection)
5	Communication port (to inverter)
6	Communication port (for parallel connection)
7	Grounding screw of the cabinet
8	BAT Knock hole(For piping, For north America )
9	CAN Knock hole(For piping, For north America )

Table 3.1 Battery control unit

General Data	
Ingress Protection	IP65
Mounting	Wall-Mounting / Ground-Mounting
Operating Temperature Range	Charging: 0°C to 50°C (32°F to 122°F) Discharging: -20°C-50°C (-4°F to 122°F)
Ambient Humidity	0% to 95% non-condensing
Cooling Method	Natural convection
Communication	CAN
Warranty [Year]	Refer to the warranty policy
Cell Designation	IFpP/41/150/112/(1P32S) M/-20+60/95
Applicable Standard	UL1973/IEC62619(Cell&Pack)/CEC/CE/ROHS/UN38.3)

Table 3.2 Battery datasheet

### 3.5 Datasheet

MODEL	B2-7.3-HV5	B2-14.6-HV5	B2-21.9-HV5
Battery Module	BU2-7.3-HV5 (32S1P 102.4V72Ah)		
No. of Modules	1	2	3
Rated Energy [kWh]	7.3	14.6	21.9
Usable Energy [kWh]	6.6	13.2	19.7
Dimension (H*W*D) [mm]	790*810*150 (31.10*31.89*5.91 inch)	1260*810*150 (49.61*31.89*5.91 inch)	1730*810*150 (68.11*31.89*5.91 inch)
Weight [kg]	81 kg (178.57 lb)	144.5(318.57 lb)	208(458.56 lb)
Nominal Voltage [V]	102.4	204.8	307.2
Operating Voltage [V]	89.6 to115.2	179.2 to 230.4	268.8 to 345.6
Charger Voltage[V]	115.2	230.4	345.6
Max. Charge Current [A]	50		
Max. Discharge Current [A]	50		
<b>Control Module</b>	<b>BC2-HV</b>		
Dimension (H*W*D)[mm]	270*810*150 (10.63*31.89*5.91 inch)		
Weight [kg]	13.1 (28.88 lb)		

## 4.

# INSTRUCTIONS FOR INSTALLATION



## 4.1 Unpacking and Inspection

### 4.1.1 Checking the Package

Although SAJ's battery have thoroughly tested and checked before delivery, it is uncertain that the battery may suffer damages during transportation. Please check the package for any obvious signs of damage, and if such evidence is present, do not open the package and contact your dealer as soon as possible.

### 4.1.2 Scope of Delivery

Please contact after sales if there are missing or damaged components.

#### Battery Control Unit Package

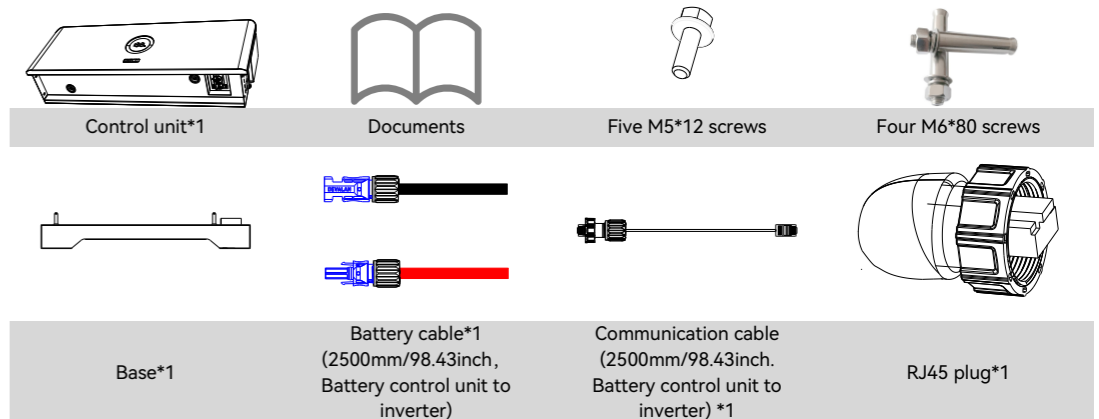

The documents include the user manual and packaging list.

#### Battery Module Package



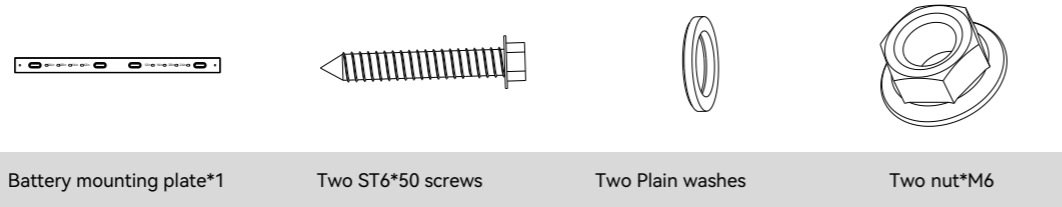

The following are optional components:



**Multi-cluster Battery Connection Accessory Package**



**Note:** When the battery connection contains over two clusters of batteries, an extra power cable is needed.

## 4.2 Installation Method and Position

### 4.2.1 Installation Position and Clearance

This device is cooled by natural convection and suggested an indoor installation or an installation under a sheltered place to prevent the battery from exposure to direct sunlight, rain and snow erosion.

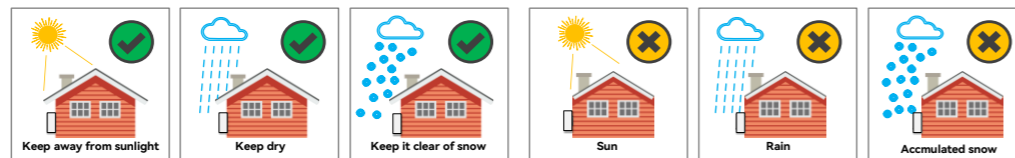

Figure 4.1  
Installation location

Please reserve enough clearance around the battery to ensure a good air circulation at the installation area. Because poor air ventilation will affect the working performance of internal electronic components and shorten the service life of the system.

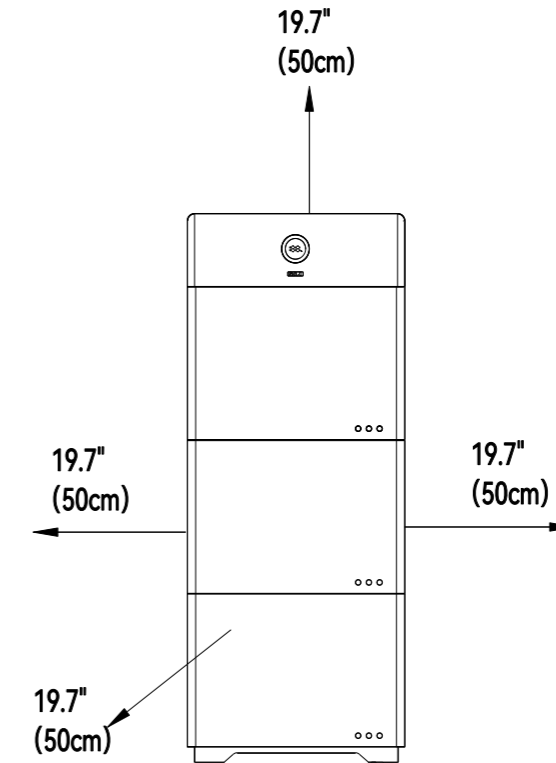

Figure 4.2  
Installation clearance

### 4.2.2 Mounting Method

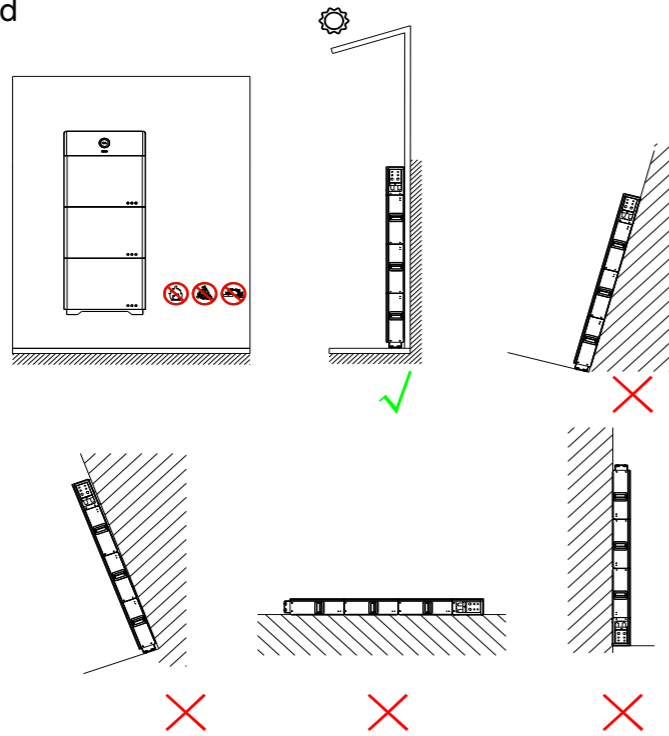

Figure 4.3  
Mounting method

- ① The equipment employs natural convection cooling, and it can be installed indoor or outdoor.
- ② Mount vertically. Never install the battery tilted forwards, sideways, horizontally or upside down.
- ③ When mounting the battery, please consider the solidity of wall for battery, including accessories, make sure the wall has enough strength to hold the screws and bear the weight of products. Please ensure the mounting bracket mounted tightly.

**Note:** Do not place the battery module face up during transportation, temporary storage, or storage.

#### Installation Environment Requirements

- Prohibit installation on surfaces without appropriate fire/insulation rating.
- The installation environment must be free of inflammable or explosive materials.
- Install the battery away from heat source.

- Do not install the battery at a place where the temperature changes extremely.
- Keep the battery away from children.
- Do not install the battery at daily working or living areas, including but not limited to the following areas: bedroom, lounge, living room, study, toilet, bathroom, theater, and attic.
- When installing the battery at the garage, please keep it away from driveway.
- Keep the battery from water sources such as taps, sewer pipes and sprinklers to prevent water seepage.
- Make sure that the wall can mount screws and supporting the weight of the battery pack before installation. For safety reason, solid wall is recommended for wall mounting, cavity wall and hollow timber wall is not allowed to install the battery system.

**Note:** When installing outdoors, the height of the battery from the ground should be considered to prevent the battery from soaking in water. The specific height is determined by the site environment.

## 4.3 Mounting Procedure

### 4.3.1 Installation Tools

Installation tools include but are not limited to the following recommended ones. Please use other auxiliary tools on site if necessary.

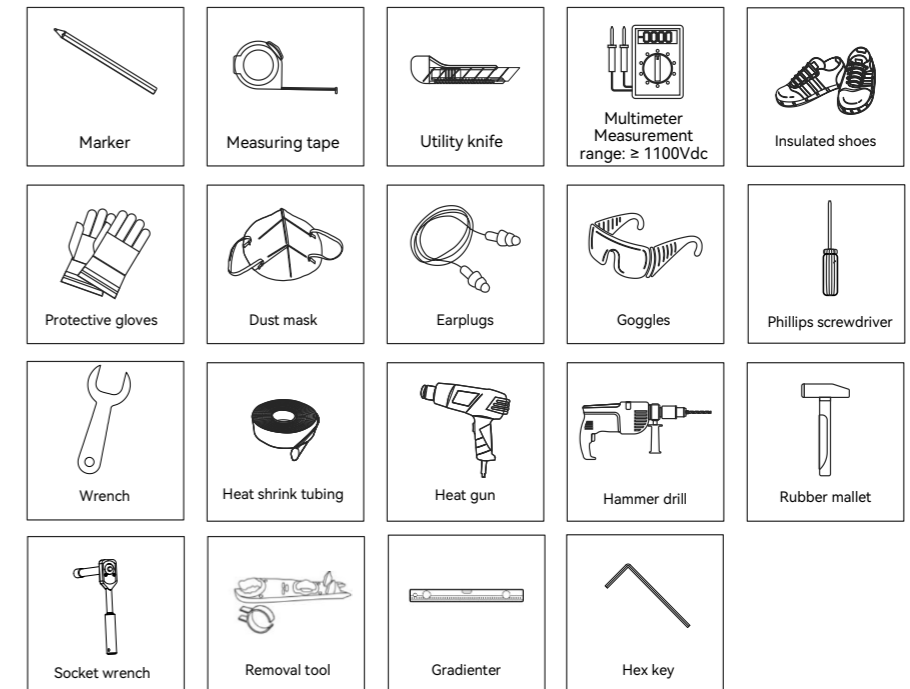

### 4.3.2 Installation Location

The battery employs either ground mounting or wall mounting, and its position is determined by the drilled holes of bracket. For ground mounted installation, you can install 3 battery packs at most in one stack. For wall mounted installation, you can install 3 battery packs at most in one stack.

Depending on the on-site installation environment, choose one of the following methods:

4.3.2.1 To wall: Ground mounting

4.3.2.2 To wall: Wall mounting

4.3.2.3 To wood studs: Ground mounting

#### 4.3.2.1 Ground Mounting (To wall)

1. Place the base on the horizontal ground with a gradienter, 40 to 55mm (1.57" to 2.17") away from the wall.

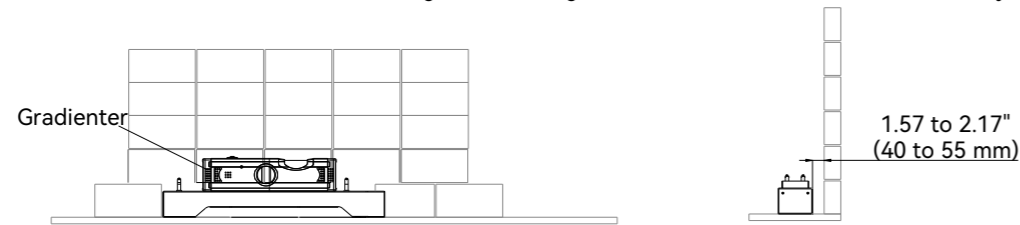

Figure 4.4  
Base installation clearance

2. Place the wall bracket horizontally against the wall with a gradienter, mark the position of holes with a marker and four holes (driller:  $\phi 8$ mm, depth: 70mm) with an electric drill and fasten the base with M6\*80 expansion screws and a socket wrench.

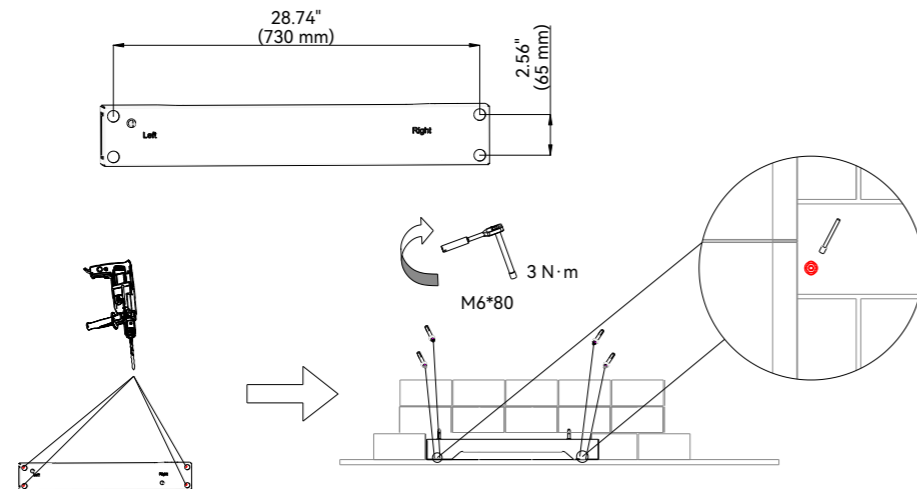

Figure 4.5  
Installation of the base

3. According to the hole positions shown in the figure below, mark the hole positions with a marker and drill the holes of  $\phi 8$  with an electric drill.

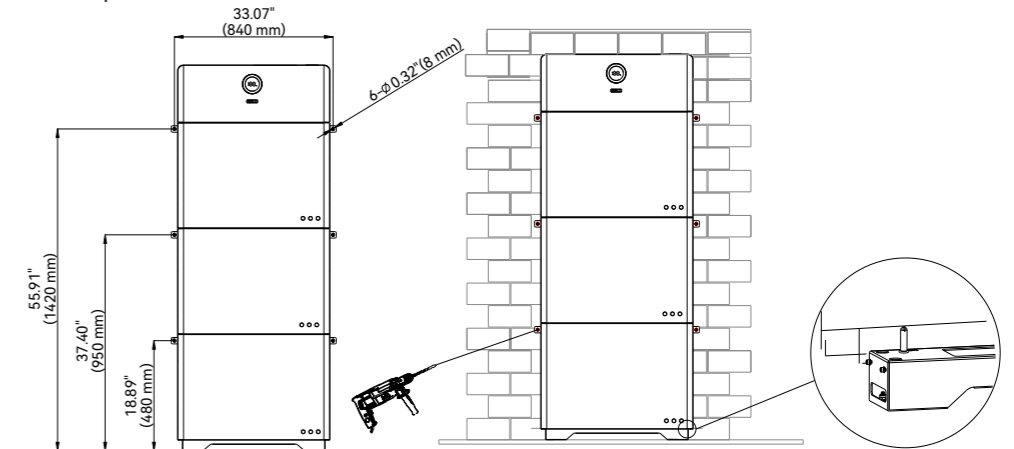

Figure 4.6  
Position of holes for battery modules installation

4. Place the battery module on the base with the pin of the base aligned with the holes at the bottom of the battery module.

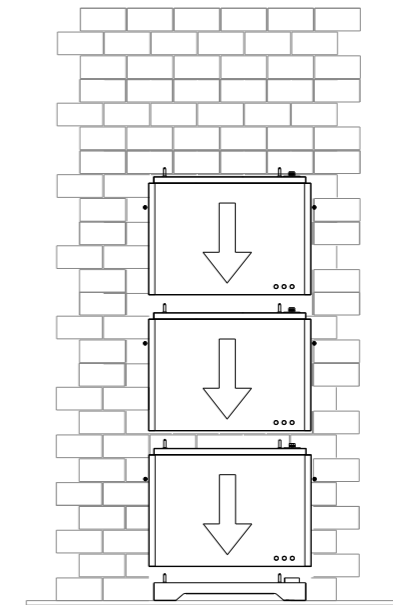

Figure 4.7  
Fixing the battery module on the base

5. Put the M6\*80 expansion screw in the hole, and then tighten the screw with a socket wrench. Use four M5\*12 screws to secure the battery module and base on both sides.

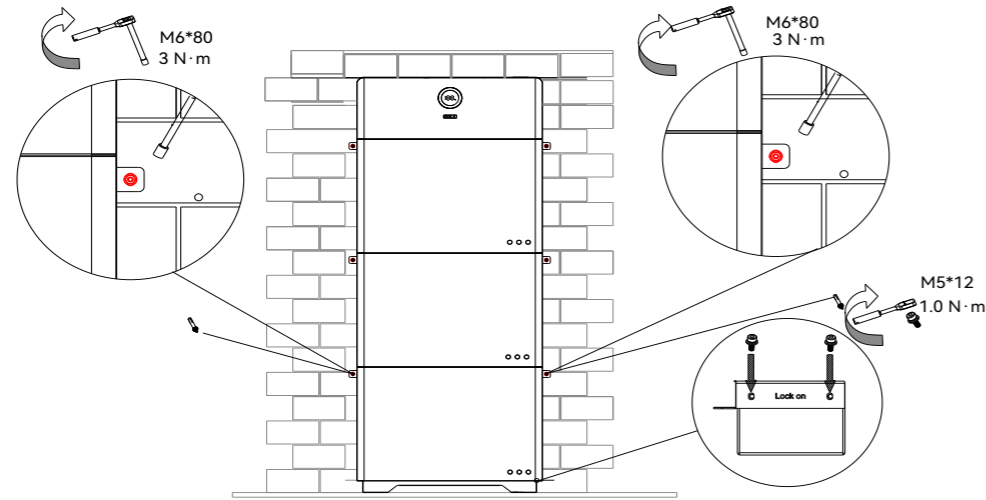

Figure 4.8  
Fixing the battery module on the wall

6. Install the rest battery modules correctly in this method. The installation steps of the battery control unit are similar in which four M5\*12 screws are used to tighten the control unit (The control unit has two M5\*12 screws on each side).

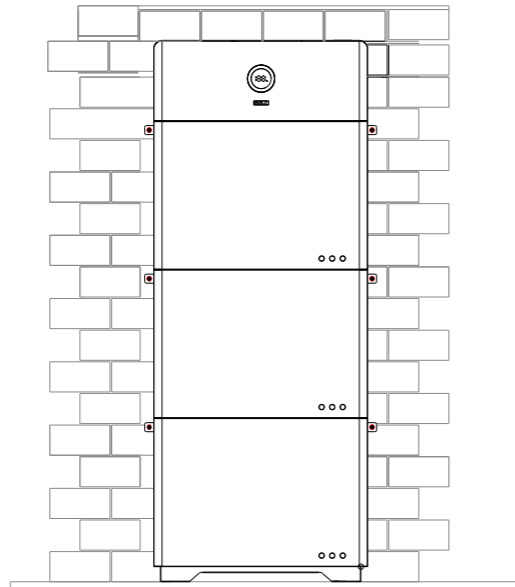

Figure 4.9  
Installation finished

### 4.3.2.2 Wall Mounting (To wall)

1. Place the wall bracket on the horizontal ground with a gradienter.

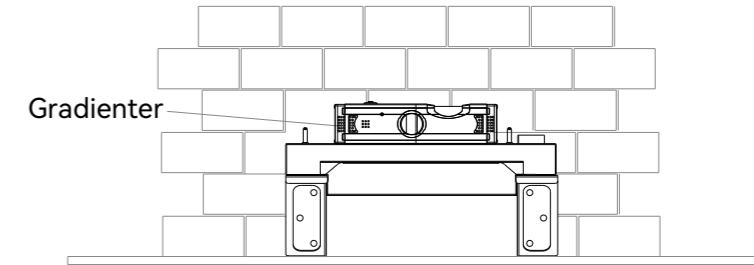

Figure 4.410  
Wall bracket installation clearance

2. Place the wall bracket horizontally against the wall with a gradienter, mark the position of six holes with a marker, and punch holes (driller:  $\phi 15\text{mm}$ , depth: 60mm) with an electric drill.

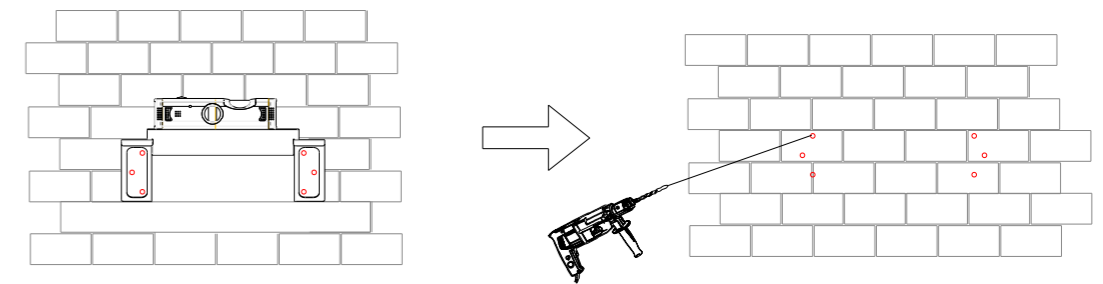
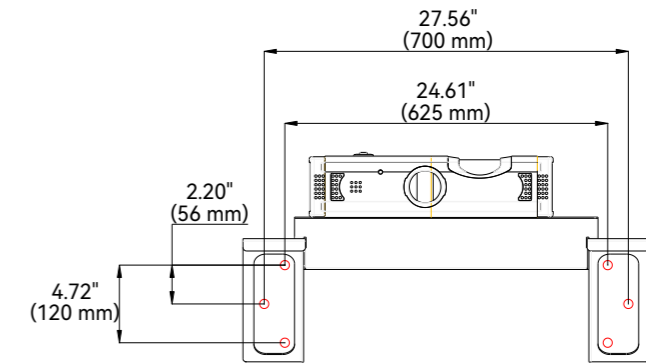

Figure 4.11  
Drilling holes for the wall bracket

3 Secure the base with the wall bracket by M6\*12 screws, and Put the M6\*80 expansion screw in the hole, and then tighten the screw with a socket wrench, and use the Level to make sure the surface of base is horizontal.

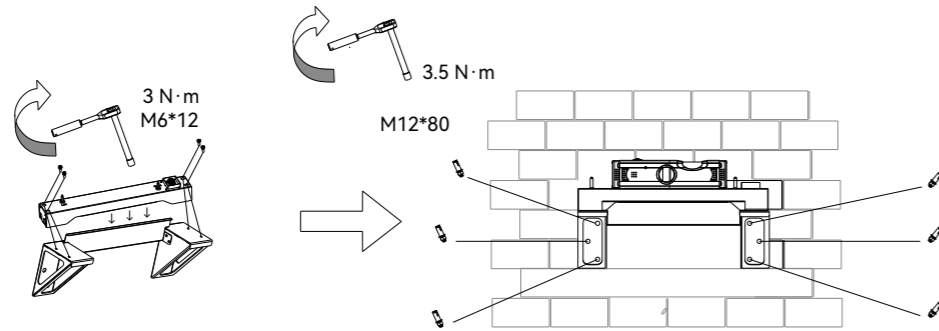

Figure 4.12  
Installation of the wall bracket and base

4. According to the hole positions shown in the figure below, mark the hole positions with a marker and drill the holes of  $\phi 8$  with an electric drill.

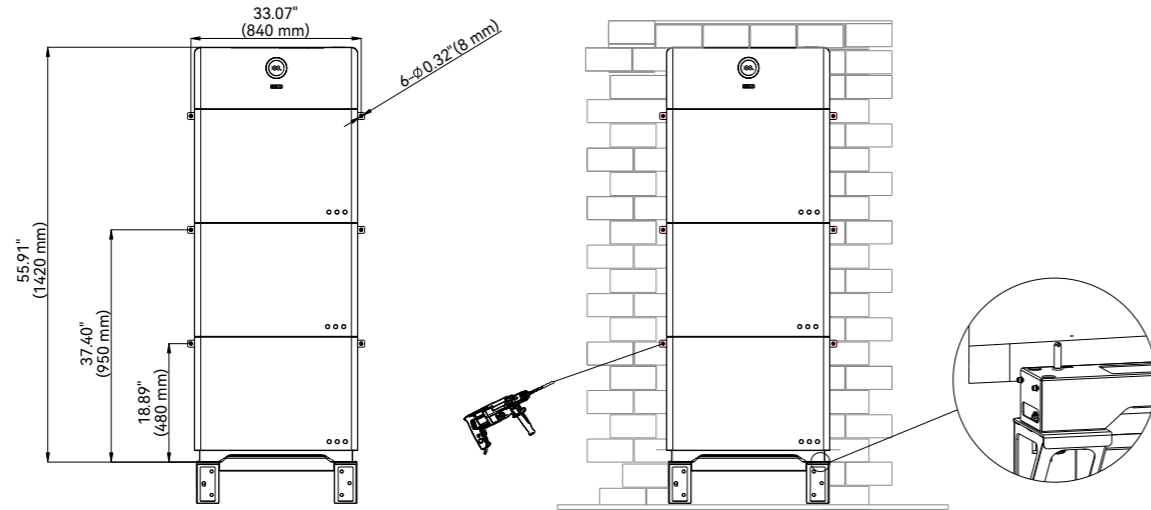

Figure 4.13  
Position of holes for battery modules installation

5 Place the battery module on the base with the pin of the base aligned with the holes at the bottom of the battery module.

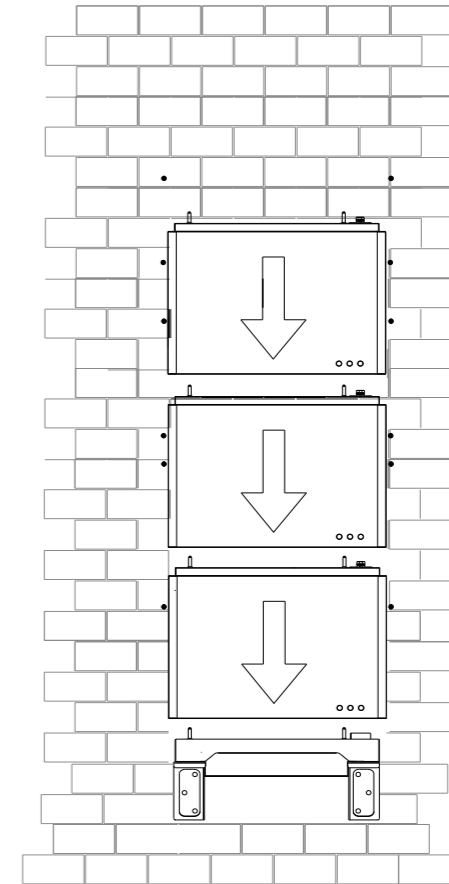

Figure 4.14  
Fixing the battery module on the base



6 Put the M6\*80 expansion screw in the hole, and then tighten the screw with a socket wrench. Use 4 M5\*12 screws to secure the battery module and base on both sides.

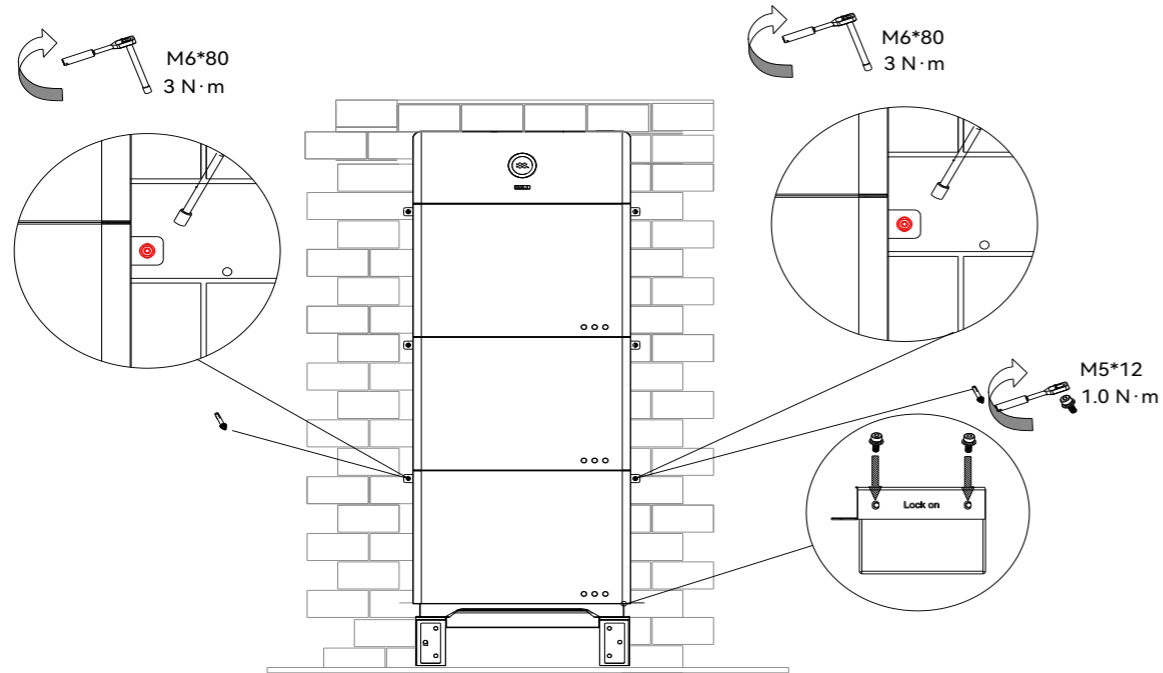

Figure 4.15  
Fixing the battery module on the wall

7. Install the rest battery modules correctly in this method. The installation steps of the battery control unit are similar in which four M5\*12 screws are used to tighten the control unit (The control unit has two M5\*12 screws on each side).

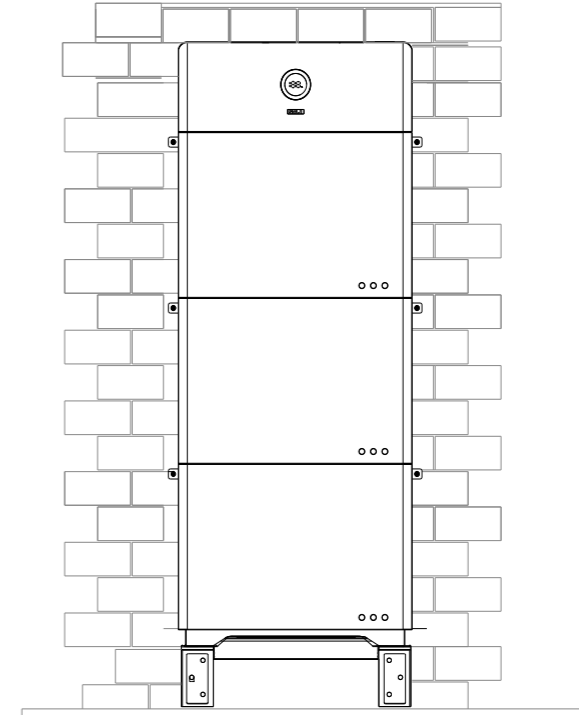

Figure 4.16  
Installation finish

### 4.3.2.3 Ground Mounting (To wood studs)

The user chooses the bracket installation distance according to the distance between their own bearing solid wood beams (12inch/16inch/20inch/24inch).

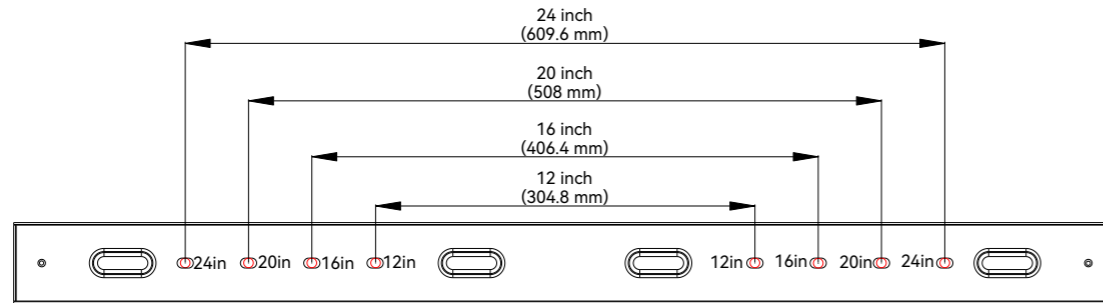

Figure 4.17  
Dimensions of battery mounting plate

#### Wood Studs (spaced at 12 to 24 inches)

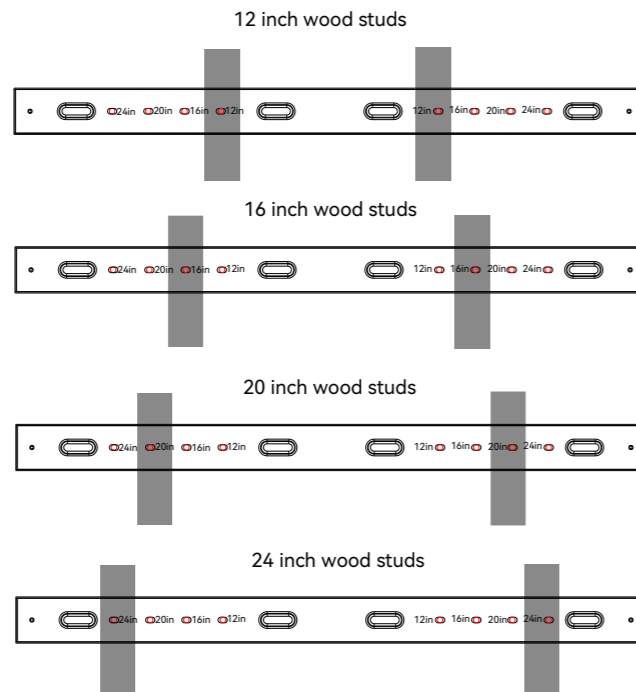

Figure 4.18  
12 to 24 inch of battery mounting plates.

The user chooses the appropriate installation size according to his own wood studs.

**The following uses the 16inch installation as an example:**

1. Place the base on the horizontal ground with a gradienter, 40 to 55mm (1.57" to 2.17") away from the wall.

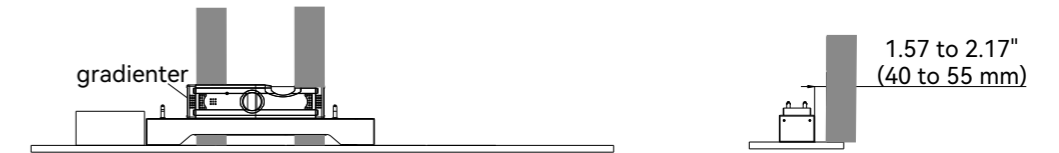

Figure 4.19  
Base installation clearance

2. Place the wall bracket horizontally against the wall with a gradienter, mark the position of holes with a marker and four holes (driller:  $\phi 8\text{mm}$ , depth: 70mm) with an electric drill and fasten the base with M6\*80 expansion screws and a socket wrench.

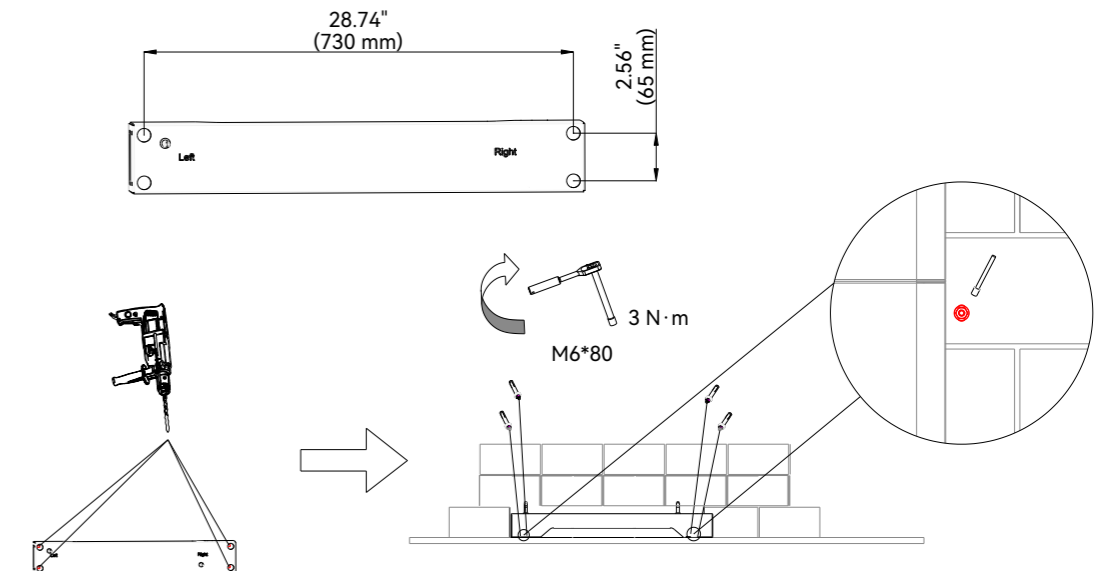

Figure 4.20  
Installation the base

3. According to the dimension of the battery module, mark the position of the battery mounting plates on the wood studs, and use an electric hammer to drill six  $\phi 8\text{mm}$  holes at the 16-inch position (Each battery module has two holes). As shown below.

**Note:** Each battery module has a battery mounting plate.

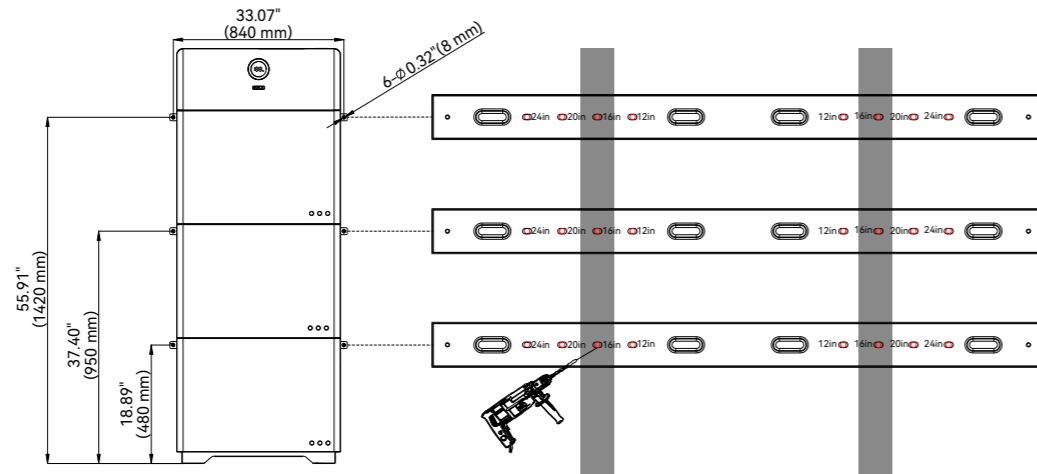

Figure 4.21  
Position of holes for battery mounting plate.

4. Secure the battery mounting plate to wood studs, tighten the six ST6\*50 screws. (Each battery module has two screws).

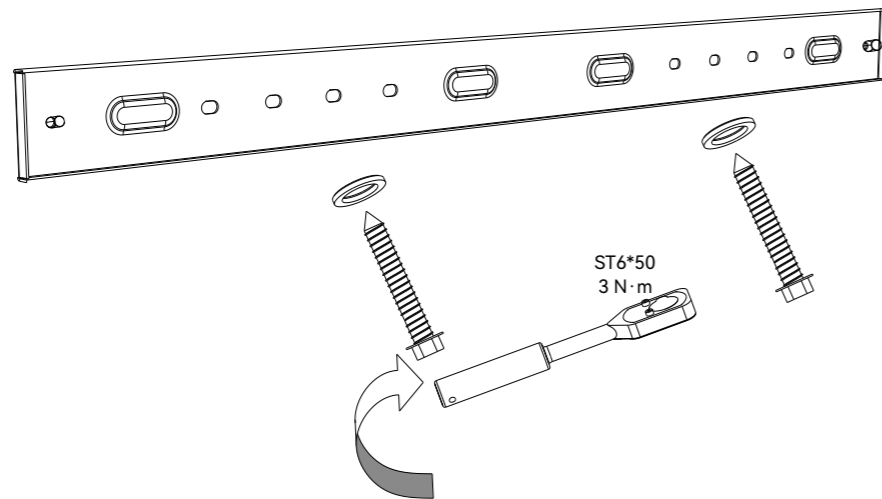

Figure 4.22  
Secure battery mounting plate.

5. Place the battery module on the base with the pin of the base aligned with the holes at the bottom of the battery module.

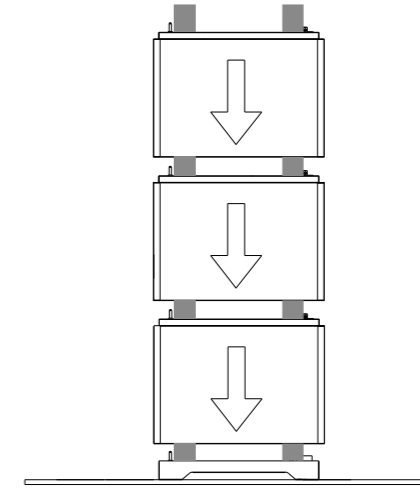

Figure 4.23  
Secure battery modules

6. Tighten the six M6 nuts on both sides of the battery. Use 4 M5\*12 screws to secure the battery module and base on both sides.

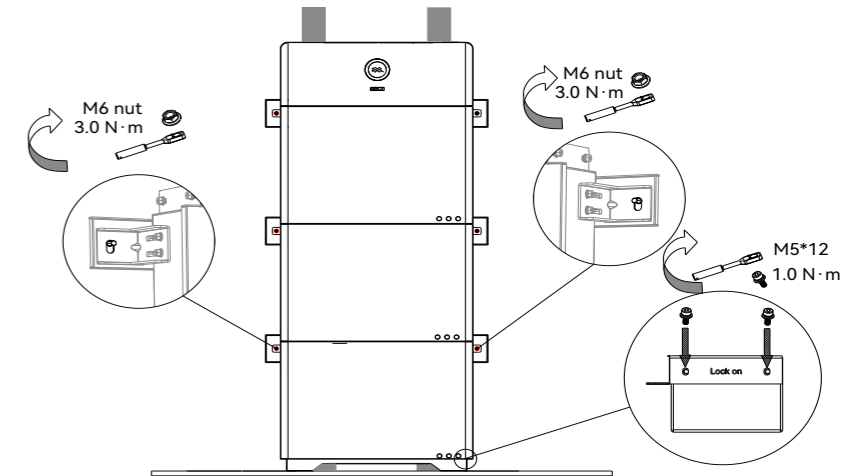

Figure 4.24  
Secure battery module

7. Install the rest battery modules correctly in this method. The installation steps of the battery control unit are similar in which four M5\*12 screws are used to tighten the control unit (The control unit has two M5\*12 screws on each side).

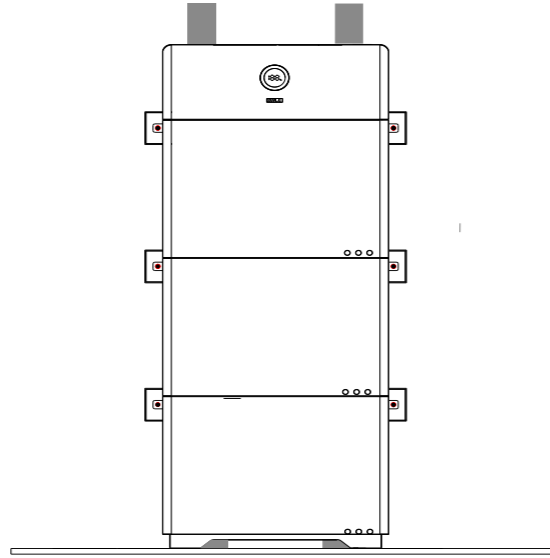
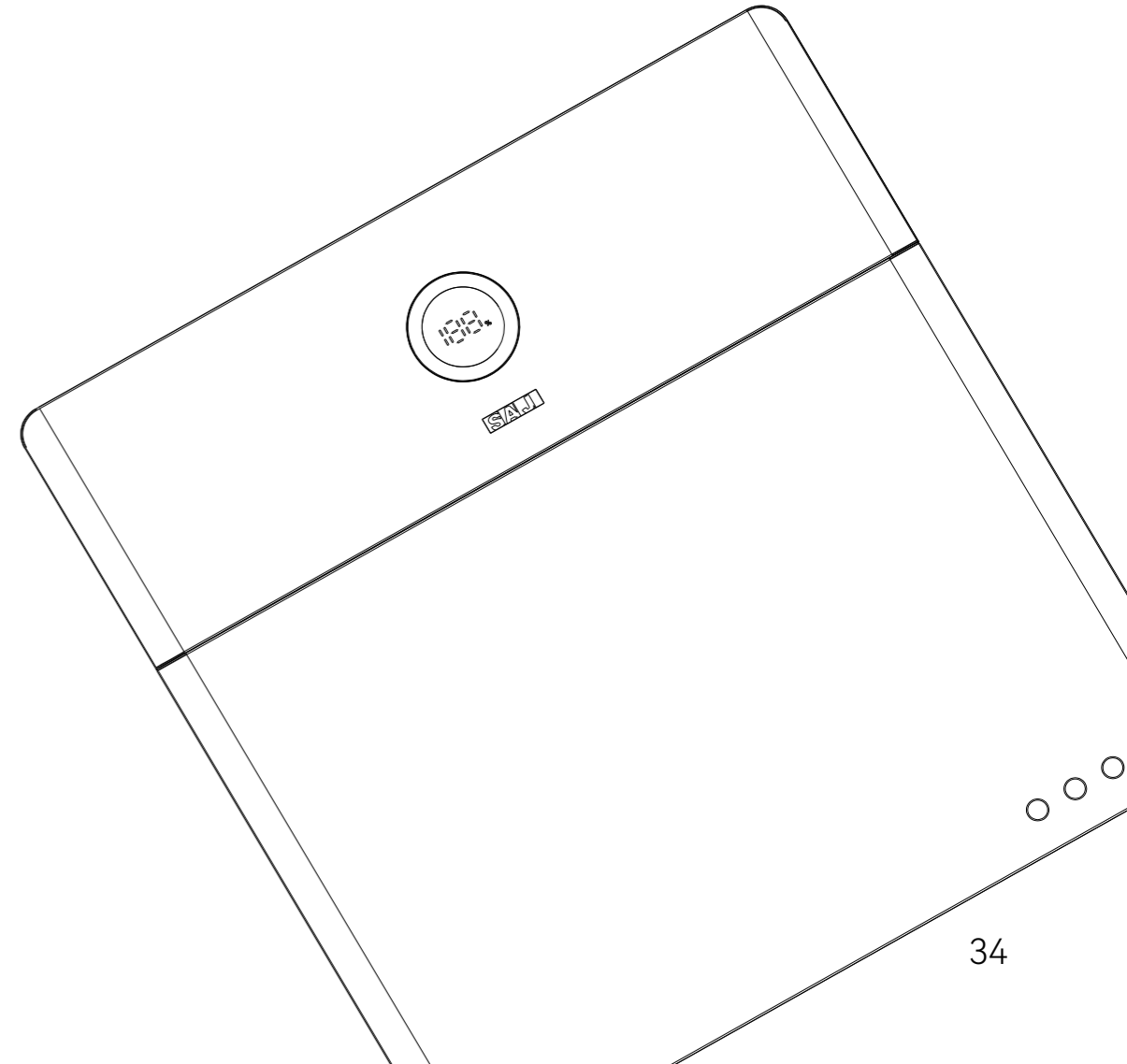

Figure 4.26  
Installation finish



## 5.

ELECTRICAL  
CONNECTION

## 5.1 Additional Grounding Cable

Electrical connection must only be operated by professional technicians. Before connection, necessary protective equipment must be employed by technicians, including insulating gloves, insulating shoes and safety helmet.

 **WARNING**

· Connect this additional grounding cable before other electrical connection.

Note: The additional cable and OT/DT terminal should be prepared by user themselves.

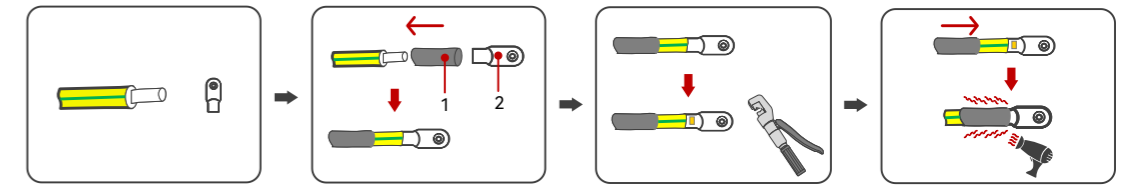

Figure 5.1  
Preparing additional grounding cable

1. Heat shrink tubing 2. OT/DT terminal

The following figure shows the grounding of the control unit.

**Note:** There is no need for additional grounding between the battery pack and the control unit. The battery pack is equipped with a grounding design.

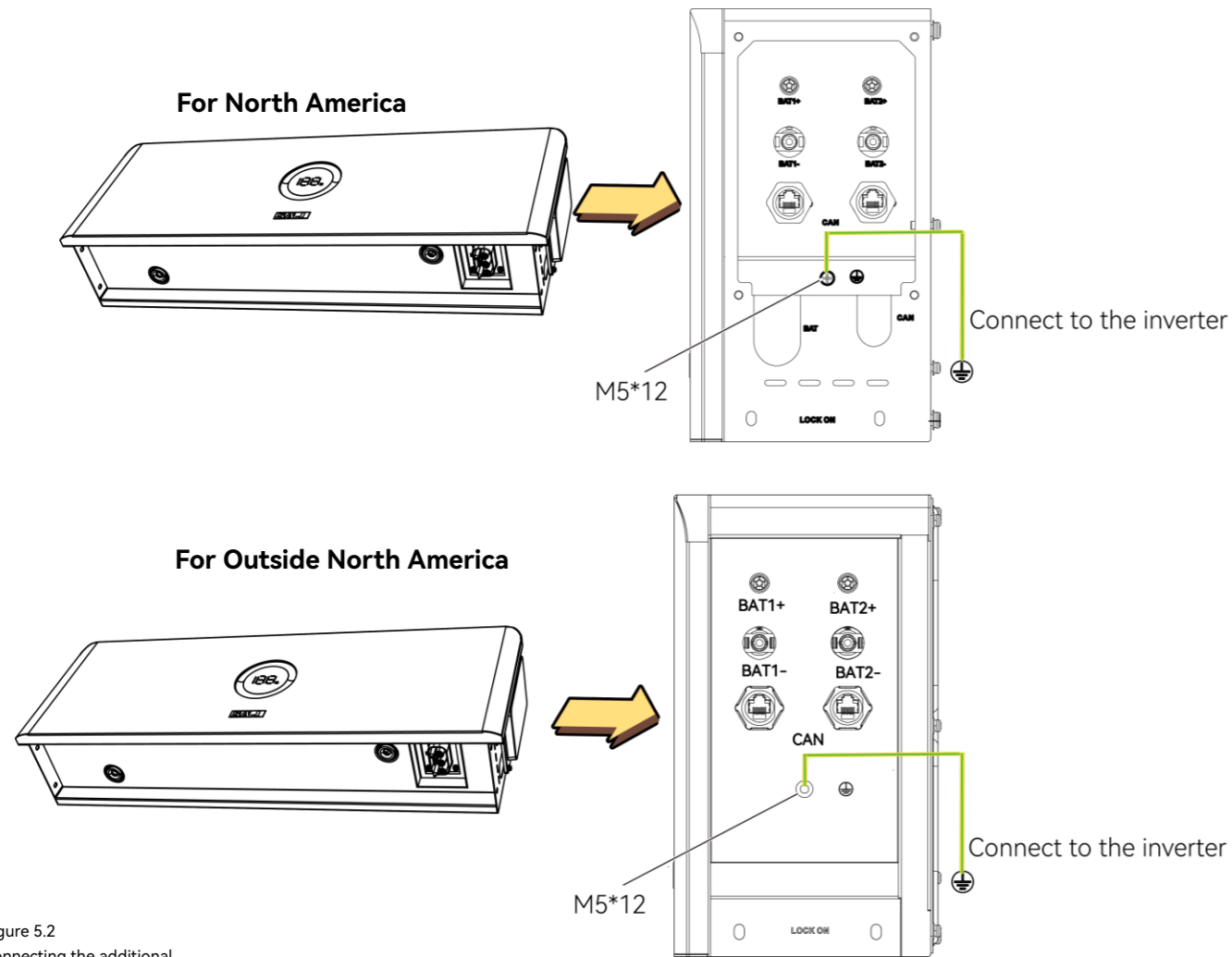

Figure 5.2  
Connecting the additional  
grounding

## 5.2 Connecting Control Unit to Battery, Battery to Battery

Connect the control unit to the battery and the battery to the battery port as shown in the figure below.

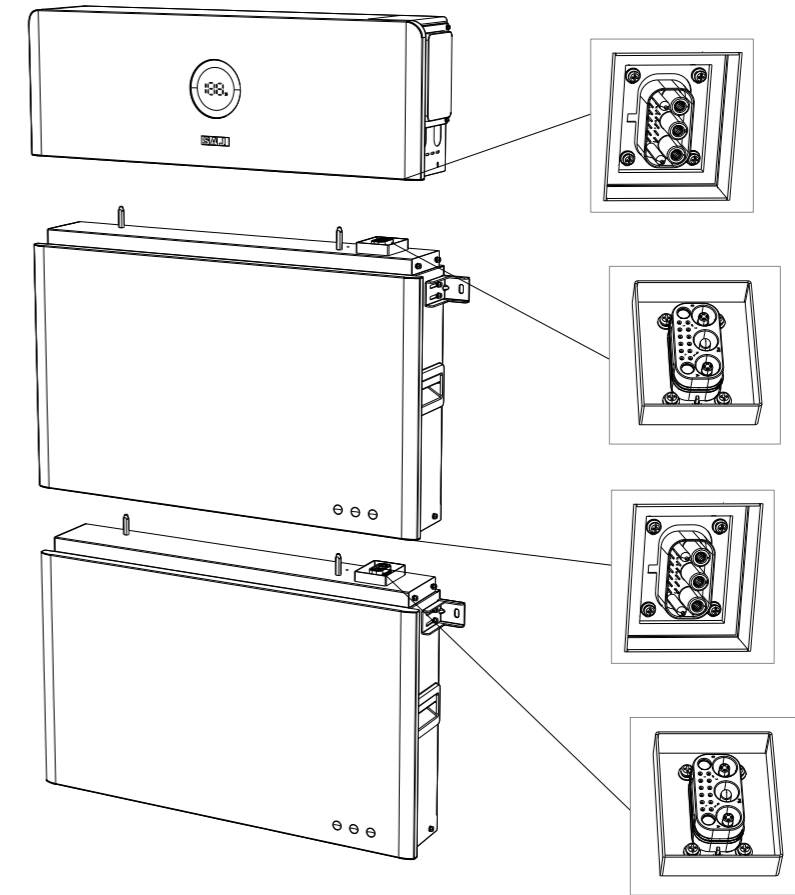

Figure 5.3  
Connecting Control Unit to Battery,  
Battery to Battery

## 5.3 Conduit installation (For North America)

Operator should use the conduits and plugs with standard size which must fit with the holes on the right side of the inverter. Conduit fittings insulated type is preferred.

Once conduit and fittings are installed, wires should go through the conduit and be locked into the corresponding terminals., Conduit fittings can be conduit joint or cable retaining rings.

The following is the water pipe fittings selection table. It is recommended to use the Conduit of  $\frac{3}{4}$ " and 1".

Standard Conduit or Pipe Size (I.D.)	Actual O.D of Pipe	Actual Hole Size
$\frac{1}{2}$ "	0.840" (21.33mm)	0.875" (22.22mm)
$\frac{3}{4}$ "	1.050" (26.67mm)	1.125" (28.57mm)
1"	1.315" (33.40mm)	1.375" (34.92mm)

Table 5.1  
Selection of conduit  
Description

### Non-parallel situation:

Step 1: Use a rubber mallet to knock the metal sheet off the hole.

Step 2: Connect Battery cable (red, 8AWG) to BAT1+, Battery cable (black, 8AWG) to BAT1-, Communication cable to CAN, and Grounding cable to the grounding terminal.

Step 3: Pass the tails of BAT1+, BAT1-, ground cable, and communication cable through the knocked hole and conduit.

Step 4: Fix the conduit on the right side of the battery control unit.

**Note:** Communication Cable Mounting Torque: 1.5-1.8 N·m.

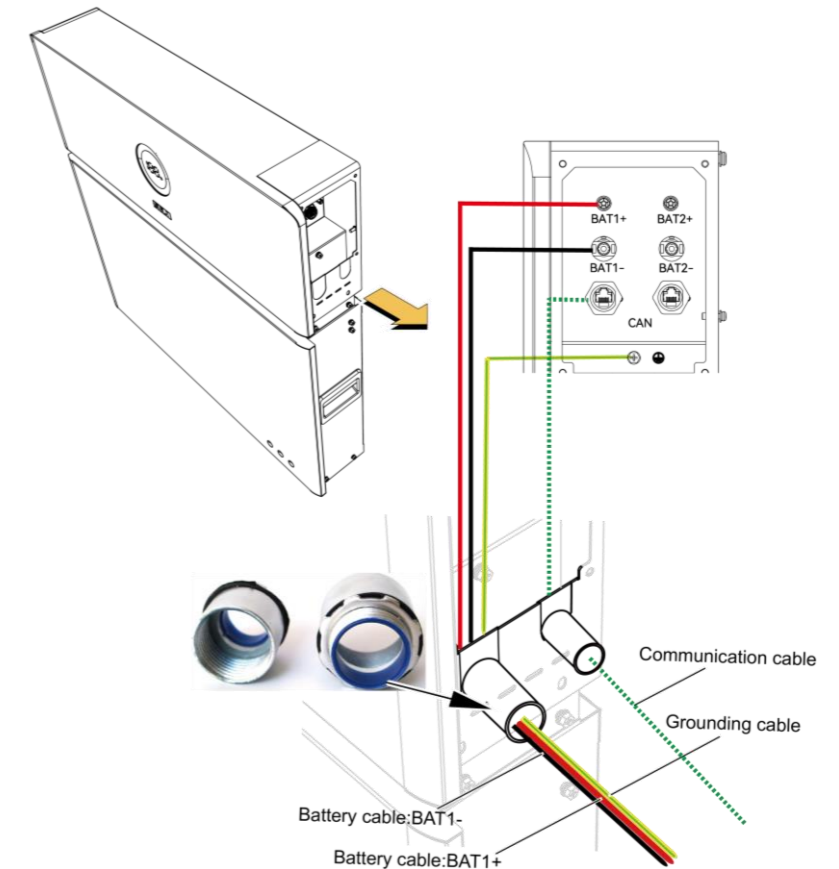

Figure 5.4  
Conduit installation

**Parallel situation:**

Step 1: Use a rubber mallet to knock the metal sheet off the hole.

Step 2: Connect Battery cable (red, 8AWG) to BAT1+, Battery cable (black, 8AWG) to BAT1-, Communication cable to CAN, and Grounding cable to the grounding terminal.

Step 3: Connect Battery cable (red, 8AWG) to BAT2+, Battery cable (black, 8AWG) to BAT2-, Communication cable to CAN.

Step 4: Pass the tails of BAT+, BAT-, ground cable, and communication cable through the knocked hole and conduit.

Step 5: Fix the conduit on the right side of the battery control unit.

**Note:** Communication Cable Mounting Torque: 1.5-1.8 N·m.

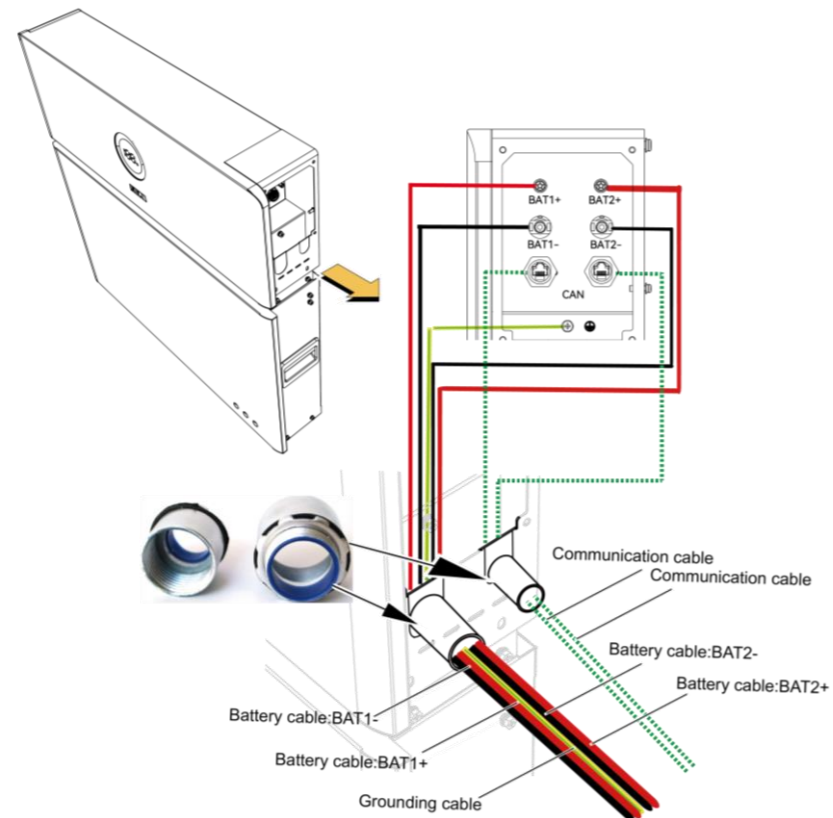

Figure 5.5  
Parallel machine Conduit installation

## 5.4 Connecting Battery to Inverter

### 5.4.1 Single-Cluster Battery Connection

Step 1: Connect battery control unit BAT1 + to inverter BAT+ and BAT1- to inverter BAT-.

Step 2: Connect the battery control unit CAN to the inverter.

Step 3: Connect the battery control unit ground cable to the inverter ground terminal.

**Notes:** It is not recommended to intertwine the Communication cable and power cables.

Communication Cable Mounting Torque: 1.5-1.8 N·m.

**For North America**

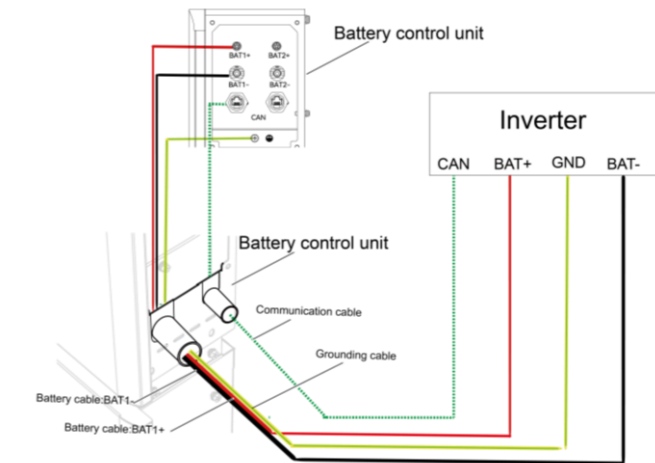

**For Outside North America**

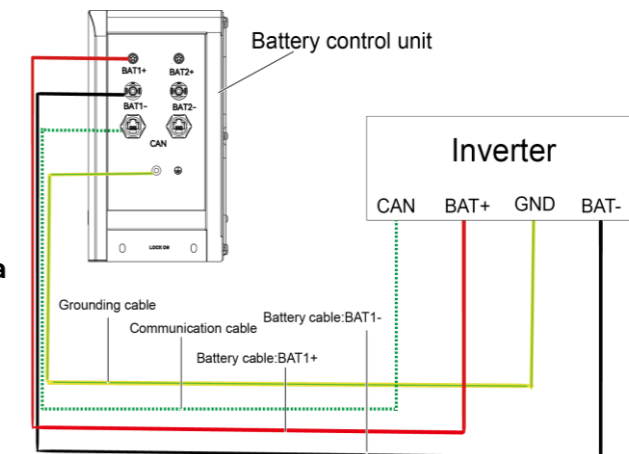

Figure 5.6  
Single-Cluster Battery Connection



### 5.4.2 Multi-cluster Battery Connection

Please follow the following diagram to connect battery and inverter. **Note:** when the connection contains over two clusters of batteries, the multi-cluster battery connection accessory package is needed. The inverter is recommended to be installed right above the first or second cluster of batteries. The height distance between the high-voltage box and the inverter shall not exceed 0.7 meters.

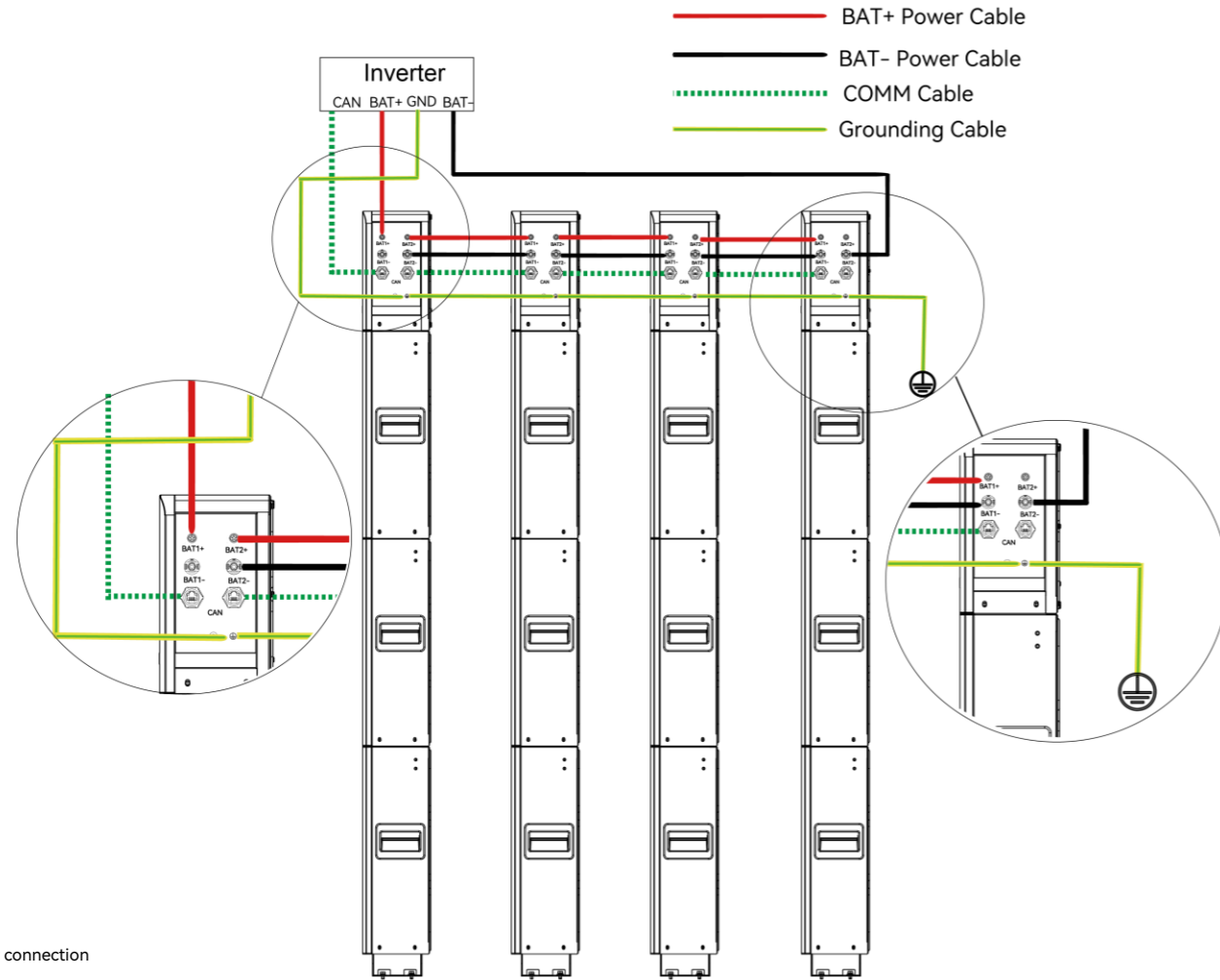
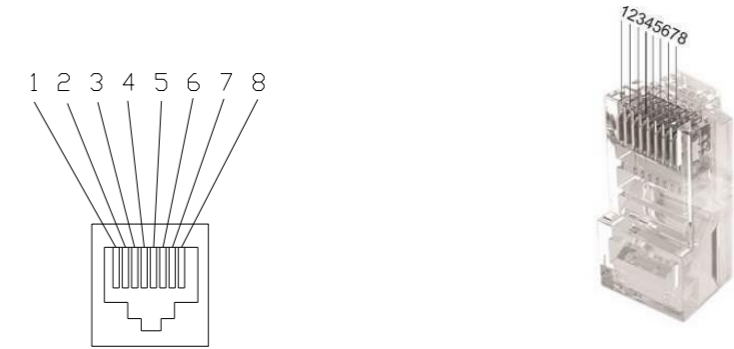

Figure 5.7  
Multi-cluster connection

### 5.5 Communication Interface

- Note:** 1) The communication cable is one end crimped, this crimped end is for battery side connection. The other end is for inverter side connection. Customer should crimp the other end of communication cable by themselves.
- 2) The pinout of RJ45 is detailed in Table 5.1 below.
- 3) Confirm that the DC switch is OFF during installation to avoid short circuit caused by wrong operation during battery wiring.
- 4) Please use the battery cable in original package.

Figure 5.8  
Pinout of RJ45



	Color	Name
1	White-orange	Blank
2	Orange	Blank
3	White-green	Blank
4	Blue	CAN-H
5	White-blue	CAN-L
6	Green	Blank
7	White-brown	RS485-A
8	Brown	RS485-B

Table 5.2  
Pinout of RJ45  
Description

6.

# COMMISSIONING



## 6.1 Start Up and Shut Down the Battery

### 6.1.1 Start Up

Step 1 (For North America): Unlock with key. Outside North America can ignore step 1 and start with step 2.

Step 2: Loosen the screw.

Step 3: Open the waterproof cover of the circuit breaker.

Step 4: Push the circuit breaker switch upward.

Step 5: Press and hold the Power switch for 2-3s, until the display is on.

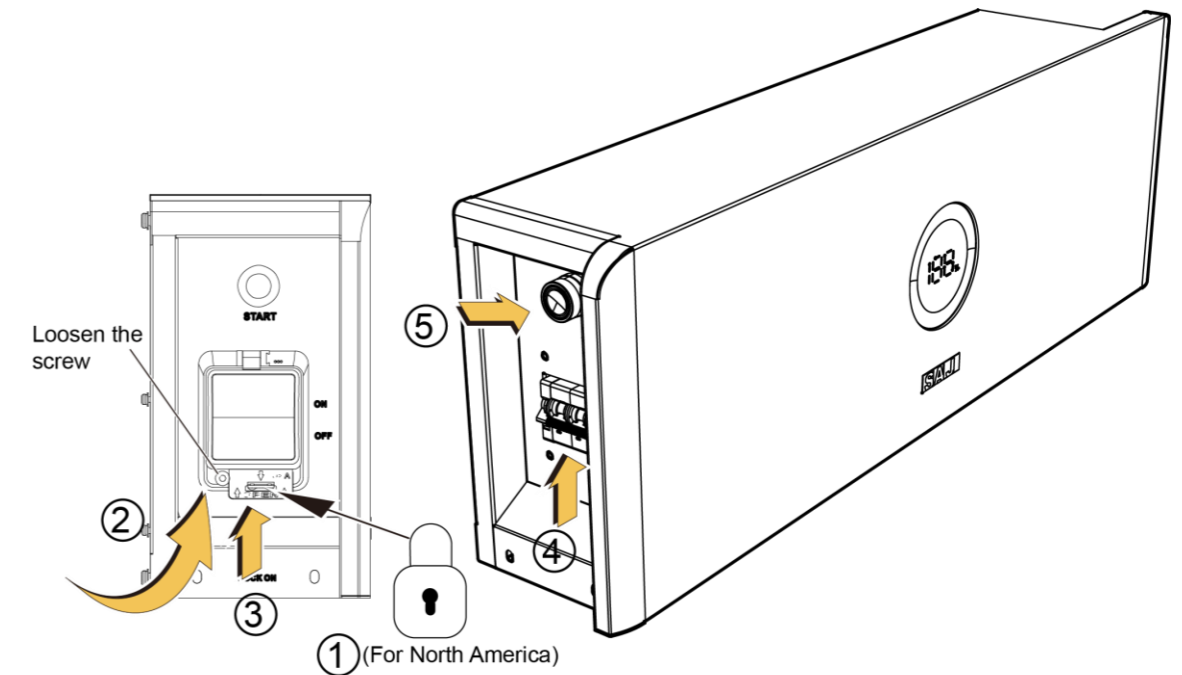

Figure 6.1  
Battery Start Up

### 6.1.2 Shut Down

- Step 1: Press and hold the Power switch for 5s, until the display is off.
- Step 2: Open the waterproof cover of the circuit breaker.
- Step 3: Push down the circuit breaker switch.
- Step 4: Tighten the screw.
- Step 5 (For North America): Lock the waterproof cover. Outside North America can ignore this step.

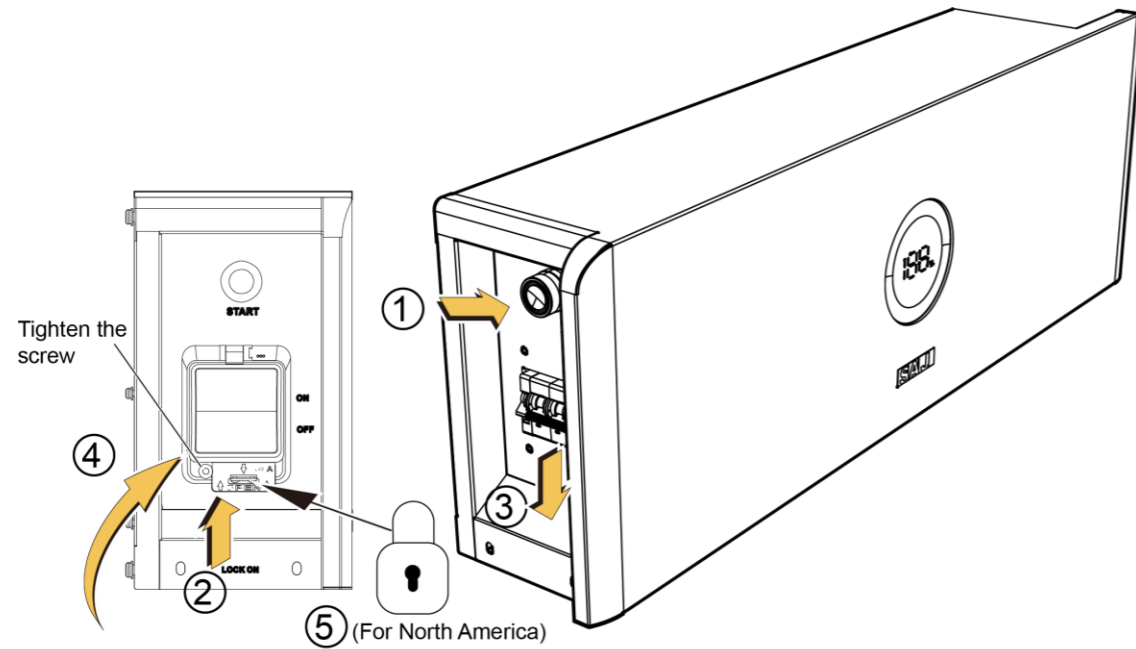

Figure 6.2  
Battery shutdown

## 6.2 Introduction of HMI (Human Machine Interface)

### System commissioning

After the wiring is completed, please refer to the inverter manual for system commission and operation.

**Note:** Turn on the circuit breaker and main switch when using the B2 battery.

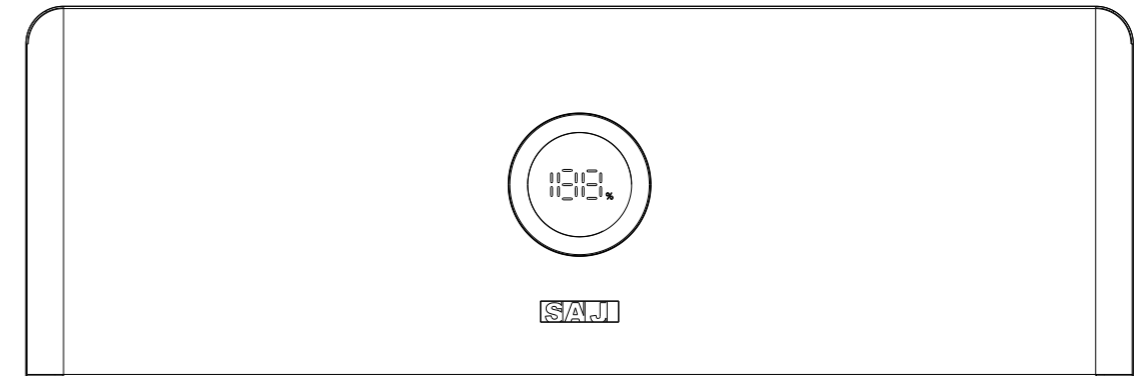

Figure 5.3  
Human-computer interface

Display	Status	Description	
Ring Light	●	Solid Green	The battery is in normal state
		Breathing Mode	The battery is in the initialization or waiting state
	●	Solid Red	An error occurs
		Breathing Mode	Software is upgrading in the battery
	○	OFF	Power off
LED Panel 1	100 %	SOC of the battery	

**Note:** One breathing cycle is 6 seconds

Table 5.1  
Interface description

### 6.3 Commissioning

Please refer to inverter manual for eSAJ home APP download and system commissioning. Please select SAJ for battery brand.

Figure 5.4  
Selecting the battery brand

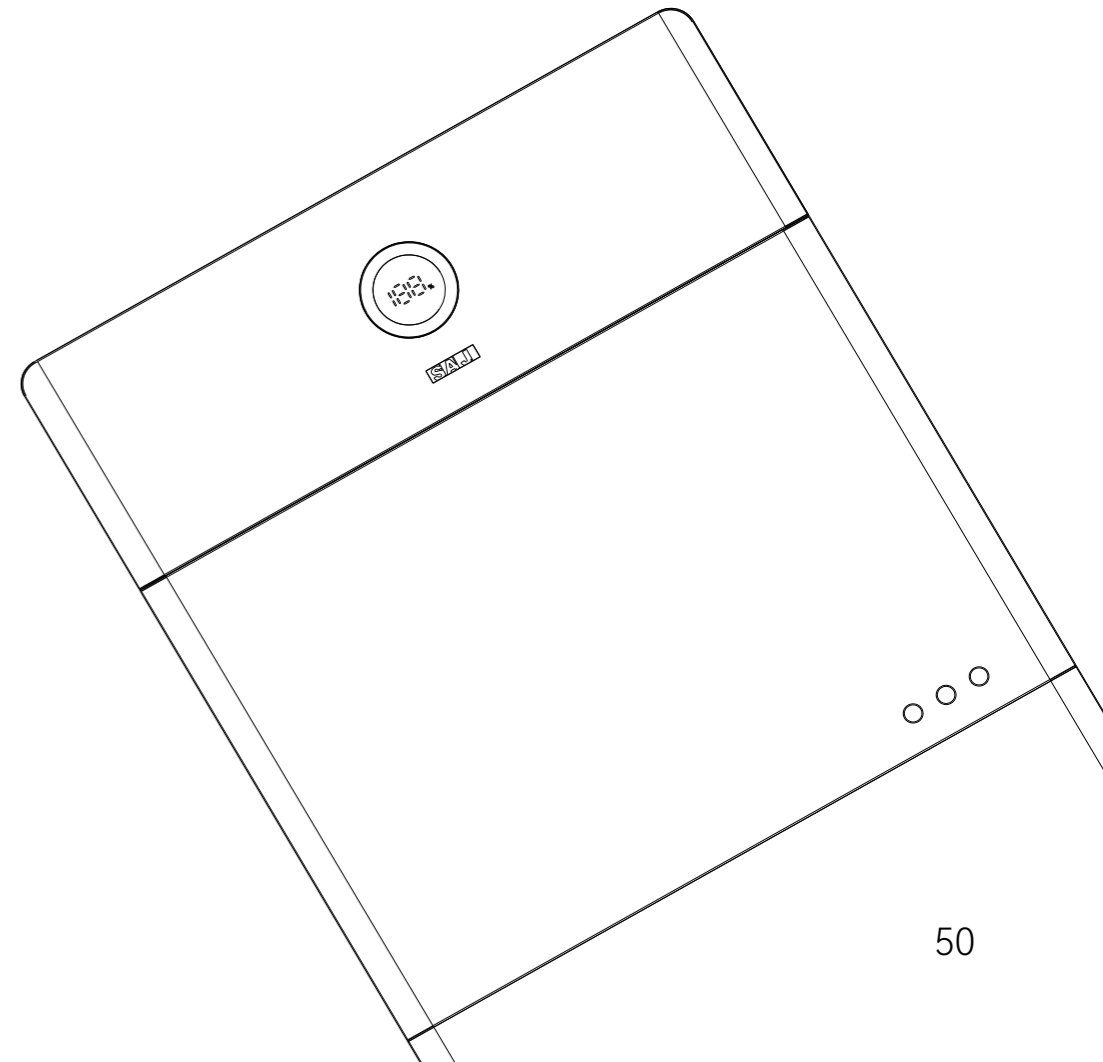
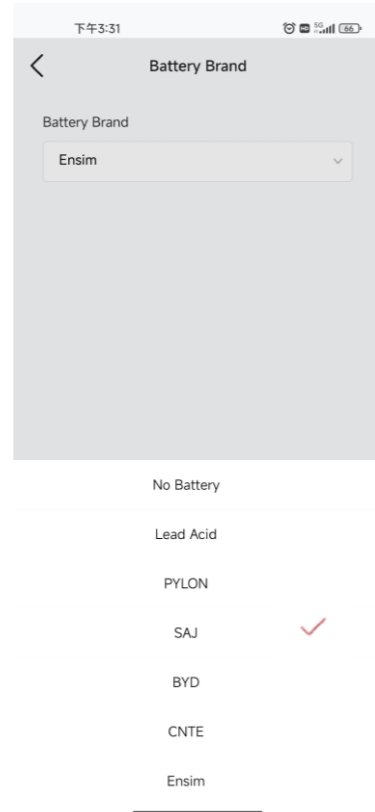

# 7.

# BATTERY MAINTENANCE



## 7.1 Transportation

Lithium batteries are dangerous goods. Passed the test of UN38.3, this product meets the transportation requirements for dangerous goods for lithium batteries. After the installation of the battery on site, the original packaging (contains the lithium battery identification) should be kept. When the battery needs to be returned to the factory for repair, please pack the battery with the original packaging to reduce unnecessary trouble.

Take care of the product during transportation and storage, keep less than 6 cartons of battery control unit in one stack, keep less than 6 cartons of battery in one stack.

**Note:** Do not place the battery module face up during transportation, temporary storage, or storage.

## 7.2 Storage

After purchasing the battery, please store it with following instructions:

- ① Please store it in a dry and ventilated environment, keep it away from heat sources;
- ② Please keep it in an environment with storage temperature as  $-10\text{ }^{\circ}\text{C} \sim 40\text{ }^{\circ}\text{C}$ , humidity  $<90\%$  RH (applicable to storage months  $< 3$ );
- ③ For long-term storage ( $3 < \text{months} < 6$ ), please put it in an environment with a temperature of  $-10\text{ }^{\circ}\text{C}$  to  $25\text{ }^{\circ}\text{C}$  and a humidity of  $< 90\%$  RH;
- ④ The battery should be stored in accordance with the storage requirements mentioned above, and the battery should be installed within 6 months since delivered from the factory and used with compatible inverters;
- ⑤ Keep the shipment module SOC less than 30% and charge the module if it has been stored for more than 6 months. Set CV to 113.6V and CC to 10A and charge the module for 1H until module terminal blocks are measured ranging from 105.6V to 112V.

### ⚠ NOTICE

- The battery remains 50% power when it is sent from the factory.
- The longer the battery is stored, lower the SOC. When the battery remaining voltage fails to reach the startup voltage requirement, the battery may be damaged.
- Judgment condition: Close the battery breaker switch and press the main switch. At this time, if the LED light is solid green, it is running normal. If the LED light is red or off, the battery is in fault.

The battery cannot be disposed of as household refuse. When the service life of the battery reaches to the limit, it is not required to return it to the dealer or SAJ, but it must be recycled to the special waste lithium

battery recycling station in the area.

## 7.3 Maintenance

Below is the recommended maintenance cycle. The actual maintenance cycle can be adjusted according to the specific installation environment of this product.

The power station scale, installation location and on-site environment will affect the maintenance cycle of this product. In sandy or dusty environments, it is necessary to shorten the maintenance cycle and increase the frequency of maintenance.

### Maintenance performed once a year:

#### ■ Battery module status

Check the following items. Take corrective actions immediately for any abnormal situations:

- Check the battery module and internal devices for damage or deformation.
- Check the internal devices for abnormal noise during operation.
- Check whether the temperature inside the battery cluster is too high.
- Check whether the internal humidity and dust of the battery module are within the normal ranges. If necessary, clean the battery module.

#### ■ Warning symbols

Ensure the warning symbols and label are legible. If necessary, clean them.

#### ■ Wire and cable

Ensure the switch gear and PCS are connected correctly.

#### ■ Corrosion

Check the battery module for internal oxidation or rust.

### Maintenance performed once every six months:

#### ■ Switch gear and battery module

Check the following items. In case of nonconformity, take corrective actions immediately:

- Check whether there are flammable objects around the battery module.
- Check whether the battery module is reliably fixed on the wall, and whether any fixing point is corroded.

- Check the switch gear and battery module for damage, paint peeling, oxidation, etc.

#### ■ Wire and cable layout

Before any operation, ensure all internal devices of the battery module are powered off.

In case of nonconformity found in inspection, take corrective actions immediately:

- Check the cable layout for short circuit and compliance with the specifications. If case of any abnormality, take corrective actions immediately.
- Check the battery module for internal seepage of water.
- Check whether the cables are loose, and tighten them according to the aforesaid torque.

#### ■ Grounding

Ensure the grounding is correct.

#### ■ Function inspection

Ensure the current, voltage and temperature in the operation record of the battery module are within the operating ranges.

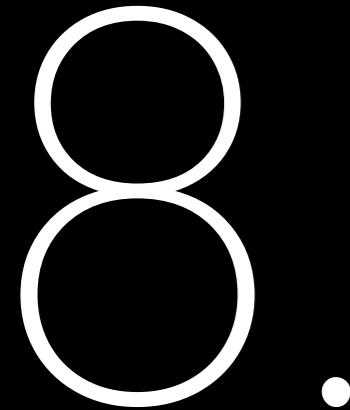

# TROUBLESHOOTING & WARRANTY



## Troubleshooting

Code	Error Name	Common Cause	Remedy
97	BMS internal communication error	<ol style="list-style-type: none"> <li>1. Communication error between battery control unit and battery module</li> <li>2. Did not install RJ45 plug, therefore battery control unit counted the number of battery modules connected mistakenly</li> </ol>	<ol style="list-style-type: none"> <li>1. Check if communication cable is connected properly</li> <li>2. Check if RJ45 plug is installed</li> </ol>
98	Battery module sequence error	<ol style="list-style-type: none"> <li>1. Cable connection is wrong</li> <li>2. Did not install RJ45 plug</li> <li>3. Communication cable connection is wrong</li> </ol>	<ol style="list-style-type: none"> <li>1. Connect the cable correctly</li> <li>2. Check if the RJ45 plug is installed</li> <li>3. Check if the communication cable is working</li> </ol>
99	Discharge overcurrent protection	Discharging current exceeds the set limit	Wait until the error is clear or restart
100	Charge overcurrent protection	Charging current exceeds the set limit	Wait until the error is clear or restart
101	Total voltage low protection	Total voltage is lower than the set limit	Force charging the battery
102	Total voltage high protection	Total voltage is higher than the set limit	Wait until the error is clear or restart
103	Single battery module voltage low protection	Single battery module voltage is lower than the set limit	Force charging the battery
104	Single battery module voltage high protection	Single battery module voltage is higher than the set limit	Wait until the error is clear or restart
105	BMS hardware error	<ol style="list-style-type: none"> <li>1. Single battery module voltage sensor error</li> <li>2. Temperature sensor error</li> <li>3. Current sensor error</li> </ol>	<ol style="list-style-type: none"> <li>1. Check if battery temperature and voltage sensor cable is in poor contact</li> <li>2. Check if current sensor cable is in poor contact</li> <li>3. Replace BMS</li> </ol>
106	Charging temperature low protection	Battery charging at <math><0^{\circ}\text{C}</math>	Wait until battery temperature increased and the error is clear

Code	Error Name	Common Cause	Remedy
107	Charging temperature high protection	Battery temperature too high	Wait until battery temperature decreased and the error is clear
108	Discharging temperature low protection	Battery temperature too low, disconnect relay to stop discharging	Wait until battery temperature increased and the error is clear
109	Discharging temperature high protection	Battery temperature too high	Wait until battery temperature decreased and the error is clear
110	Relay error	1. Cathode or anode relay is adhesive 2. Cathode or anode relay is unable to close	Replace relay
111	Pre-charge error	1. Pre-charge relay damaged 2. Pre-charge resistor open-circuit 3. BMS damaged	1. Replace pre-charge relay 2. Replace pre-charge resistor 3. Replace BMS
112	Insulation error	Battery module has electricity leakage	Contact battery supplier
113	BMS supplier incompatibility	BMS of battery module and battery control unit are incompatible	Check if the model of battery module and battery control unit are compatible
114	Battery cell supplier impartibility	Supplier of battery module and battery cell are incompatible	Check if the model of battery module is correct
115	Battery cell incompatibility	Battery cells are incompatible	Check if the model of battery module is correct
116	Voltage inconsistency	Battery module voltage are inconsistent	Check if the model of battery module is correct
117	Circuit breaker is open	1. Circuit breaker is open 2. Circuit breaker auxiliary contact error	Replace circuit breaker
118	Temperature difference is too wide	1. Temperature sensor error 2. Battery life span	1. Check if temperature sensor cable is in poor contact

Code	Error Name	Common Cause	Remedy
119	Voltage difference is too wide(Class II)	1. Sensor cable is loose 2. Battery life span	1. Check if voltage sensor cable is in poor contact 2. Replace BMS
120	Voltage difference is too wide (Class I)	1. Sensor cable is loose	1. Check if voltage sensor cable is in poor contact 2. Replace BMS
121	BMS over temperature protect	1. Ambient temperature is high 2. Overload	1. Check if ambient temperature is high 2. Check if overloaded
122	Short circuit protect	P+ and P- short circuit	Check if the cable connected correctly
123	Total Voltage match failed	Connection is wrong	Contact technical support to locate the fault
124	The system is locked	System is faulty	Contact technical support to locate the fault
125	FUSE error protection	Fuse is damaged	Contact technical support to locate the fault
126	Voltage on charging port is high protection	Inverter output voltage is high	Contact technical support to locate the fault

## Warranty

Please go to SAJ website for warranty conditions and terms  
<https://www.saj-electric.com/>